



*FEDERATION INTERNATIONALE  
DE MOTOCYCLISME*

**TECHNICAL RULES  
TRIAL**

**2025**

*RÈGLEMENTS TECHNIQUES  
TRIAL*

# Technical Rules Trial

# 2025

## *Règlements Techniques Trial*

YEAR 2025		
Version	Applicable as from	Modified articles
0	01.01.2025	3

## Table of Contents

A.	INTRODUCTION .....	3
B.	DEFINITION.....	3
1.	FREEDOM OF CONSTRUCTION.....	3
2.	CATEGORIES AND GROUPS OF MOTORCYCLES.....	3
3.	CLASSES .....	3
4.	TELEMETRY .....	4
5.	DEFINITION OF A PROTOTYPE .....	4
6.	PROHIBITED MATERIAL.....	4
7.	DATA RECORDING .....	5
8.	LEGAL CONFORMITY OF THE MOTORCYCLES AND THEIR REGISTRATION PLATES.....	5
9.	DANGEROUS MACHINES .....	5
C.	MOTORCYCLE AND ENGINE .....	5
10.	SUPERCHARGING.....	5
11.	STARTING DEVICES.....	5
12.	FUEL TANKS .....	6
13.	FUEL AND LUBRICANT .....	6
14.	FUEL TESTING.....	6
15.	HANDLEBAR.....	6
16.	CONTROL LEVERS.....	8
17.	THROTTLE CONTROLS.....	8
18.	IGNITION CUT-OUT SWITCH .....	8
19.	RIMS.....	9
20.	TYRES.....	9
21.	OPEN TRANSMISSION GUARDS .....	10
22.	DRIVEN SPROCKET GUARDS.....	11
23.	EXHAUST PIPES AND SILENCERS .....	11
24.	FOOTRESTS.....	12
25.	BRAKES .....	13
26.	MUDGUARDS AND WHEEL PROTECTION.....	14
27.	MOTORCYCLE WEIGHTS .....	15
D.	RIDER'S EQUIPMENT .....	15
28.	CLOTHING AND PROTECTORS .....	16
29.	FOOTWEAR.....	17
30.	GLOVES.....	17
31.	EYE PROTECTION.....	17
32.	HELMET .....	17
E.	TECHNICAL VERIFICATION.....	21
33.	PREPARATION.....	21
34.	FMNR CHIEF TECHNICAL STEWARD AND TECHNICAL STEWARDS .....	21
35.	FIM TECHNICAL DIRECTOR .....	22
36.	TECHNICAL VERIFICATION EQUIPMENT .....	23
37.	BADGE OF THE FIM.....	23
38.	PRESENCE AT THE TECHNICAL CONTROL.....	24
39.	MEASUREMENT OF CAPACITY .....	24
40.	VERIFICATIONS .....	25
41.	DECISION .....	27
42.	FINAL EXAMINATION.....	28
F.	ADDITIONAL SPECIFICATIONS FOR ELECTRIC POWERED VEHICLES (EPVs, Group J).....	28
43.	EPV INTRODUCTION.....	28
G.	ADDITIONAL SPECIFICATIONS FOR TRIAL VINTAGE MOTORCYCLES .....	28
44.	TVM INTRODUCTION .....	28
H.	SOUND CONTROL .....	29
I.	FUEL REGULATIONS .....	29
J.	DIAGRAMS.....	30

Any references to the male gender in this document are made solely for the purpose of simplicity, and refer also to the female gender except when the context requires otherwise.

## **A.INTRODUCTION**

The term motorcycle covers all vehicles having, in principle, less than four wheels, propelled by an engine and designed essentially for the carriage of one or more persons of which one is the rider of the vehicle. The wheels must normally be in contact with the ground except momentarily or in certain exceptional circumstances. Furthermore, in order to traverse certain surfaces one or all of the wheels can be replaced with skis, rollers or chains.

## **B.DEFINITION**

### **1. FREEDOM OF CONSTRUCTION**

A motorcycle must conform to the requirements of the FIM regulations, to the Supplementary Regulations, as well as to a number of specific conditions that the FIM may require for certain competitions. No restriction is placed on the make, construction or type of motorcycle used.

All solo motorcycles (Group A1) must be constructed in such a way that they are entirely controlled by a rider. Motorcycles with Sidecars (Group B) must be constructed to carry a passenger.

### **2. CATEGORIES AND GROUPS OF MOTORCYCLES**

Motorcycles are divided into categories and groups which must be observed for all meetings.

In principle, it is forbidden for different categories, groups and classes to compete together, unless the Supplementary Regulations state otherwise.

#### **Category I**

Vehicles propelled by a thermal engine and by the action of only one driving wheel in contact with the ground in only one direction.

#### **Category II**

Vehicles propelled by an electrical engine and the action of only one driving wheel in contact with the ground in only one direction (see Art. F).

### **3. CLASSES**

Groups are again separated into classes according to cylinder capacities as detailed below. Generally, these classes must be observed for all meetings.

Class*	over (cc)	up to (cc)	Electrical Engine **
50	-	50	No
TRIAL3	-	125	Class "A" only
TRIAL2	-	350 (4 strokes)	Class "A" or Class "B"
		300 (2 strokes)	
TRIAL2 WOMEN	-	300	Class "A" or Class "B"
TRIALGP	250	-	Class "A" or Class "B"
TRIALGP WOMEN	<del>425</del> 100	-	Class "A" or Class "B"
TDN TDN-IT WTDN	-	-	Class "A" or Class "B"
TVM TVMT	-	-	No
X-TRIAL	250	-	Class "A" or Class "B"
X-TDN	250	-	Class "A" or Class "B"

(\*) Age limitations in accordance with Sporting Regulations

(\*\*) Refer to Article F

#### 4. TELEMETRY

No signal of any kind may be transmitted to or from a moving motorcycle.

The only authorised equipment for transmitting data are:

- time keeping transponder
- automatic lap timing devices
- approved on-board cameras (with prior written approval from the Championship Promoter/Organiser).

#### 5. DEFINITION OF A PROTOTYPE

A prototype motorcycle is a vehicle which must conform to the safety requirements as required by the FIM Sporting Code and Appendices applicable to the type of competition for which it is to be used.

#### 6. PROHIBITED MATERIAL

Concerning material verification, in case of doubt, a sample or the part in question shall be taken and analysed at a Material Testing laboratory.

##### 6.1. Titanium

The use of titanium in the construction of the frame, the front forks (referred only to structural parts: legs, tubes, etc), the handlebars, the swinging arms, the wheel- and swinging arm-spindles is forbidden.

The use of titanium alloy nuts and bolts is allowed.

## **6.2. Carbon fibre**

The use of carbon fibre reinforced materials is authorised (with the exception of handlebars and wheel rims).

## **6.3. Ceramic materials**

The use of ceramic parts is forbidden.

## **7. DATA RECORDING**

The use of data recording devices is allowed.

## **8. LEGAL CONFORMITY OF THE MOTORCYCLES AND THEIR REGISTRATION PLATES**

Motorcycles and their equipment must comply with the national legal requirements for road traffic of the country in which the vehicle is registered and with other rules specified in the Supplementary Regulations.

The electrical generator must operate continuously and normally with respect to current and voltage during the competition and at post competition control. The electrical connections must be retained.

## **9. DANGEROUS MACHINES**

If, during practice or the race, a Technical Steward finds that a machine is defective and might constitute a danger to other riders, he must immediately notify the Clerk of the Course/FIM Race Director or his deputy. It is their duty to exclude such a machine either from the practice or from the race itself.

## **C.MOTORCYCLE AND ENGINE**

---

### **ENGINE**

---

## **10. SUPERCHARGING**

Supercharging by means of a device of any kind is forbidden in all meetings.

An engine, whether 2-stroke or 4-stroke, coming within any one of the recognised classes (determined by the capacity of the working cylinder) shall not be considered as supercharged when, in respect of one engine cycle, the total capacity, measured geometrically, of the fuel charging device or devices, including the capacity of the working cylinder (if used for injecting the fuel), does not exceed the maximum capacity of the class in question.

## **11. STARTING DEVICES**

Starting devices for the engine are compulsory.

---

## Fuel

---

### 12. FUEL TANKS

The fuel tank and oil tank must be securely mounted.

Fuel tanks shall only be filled in the Paddock or in officially designated "refuelling area(s)".

These area(s) shall be equipped with fire extinguishers and environmental mats. The Promoter/Organiser shall inform the participants on the location of these areas.

### 13. FUEL AND LUBRICANT

All vehicles must be fuelled with one of these:

- unleaded fuel (from public pump station or race type)
- a mixture of unleaded fuels
- a mixture of unleaded fuel(s) and lubricant in the case of 2-stroke engines.

The unleaded fuel or the mixture of unleaded fuels used must comply with the FIM specifications as set out in FIM Fuel Regulation.

The mixture of unleaded fuel(s) and lubricant must comply with the FIM specifications as set out in FIM Fuel Regulation.

If a Riders/team is using Race Fuel, they must declare to the FIM Technical Director (or the FMNR Chief Technical Steward when there is no FIM Technical Director appointed) the make and type of fuel to be used during practices and race(s), upon presentation of the rider/team's motorcycle(s) at the initial Technical Verifications. They are also recommended to provide a certificate issued by the fuel company which certify that the fuel has been tested and is in conformity with FIM specifications.

#### 13.1. Oxidizer

Only ambient air may be mixed with the fuel as an oxidant.

### 14. FUEL TESTING

The FIM may require fuel controls, i.e. controls of the unleaded fuel, mixture of unleaded fuels or mixture of unleaded fuel and lubricant, used by riders/teams at events. The sampling procedure is described in the FIM Fuel Regulation.

---

## Controls

---

### 15. HANDLEBAR

#### 15.1. Handlebar width

The width of handlebars must be not less than 600 [mm] and not more than 850 [mm].

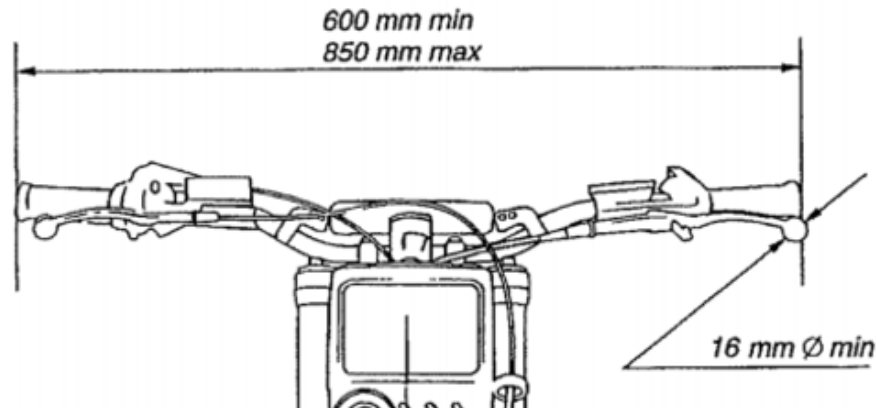

Figure 1 : Handlebar length

### 15.2. Handlebar covering

The handlebars must be equipped with a protection pad on the cross bar. Handlebars without a cross member must be equipped with a protection pad located in the middle of the handlebars, covering completely the handlebars clamps.

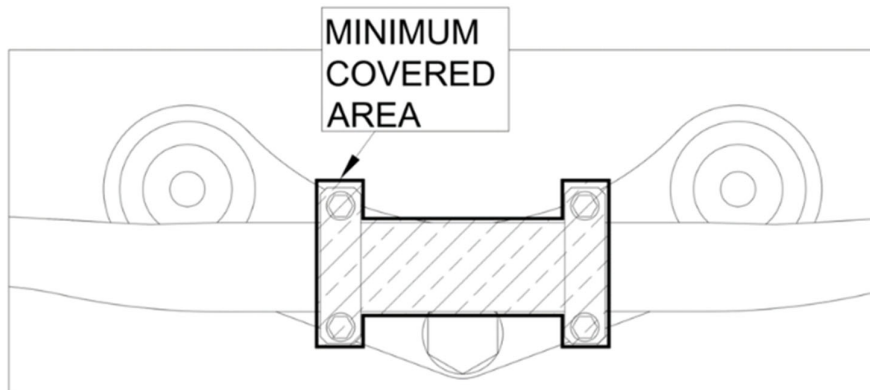

Figure 2 : Handlebar covering

### 15.3. Handlebar clamp

Handlebar clamps must be very carefully radiused on all exposed edges and engineered so as to avoid any fracture points in the handlebar.

### 15.4. Handlebar ends

Exposed handlebar ends must be plugged with a solid material or rubber covered.

### 15.5. Hand protectors

When hand protectors are used, these must be made of a shatter-resistant material and have a permanent opening for the hand.

### 15.6. Handlebar material

Handlebars made of composite materials are not authorised.



### **15.7. Handlebar repair**

Repair by welding of light alloy handlebars is prohibited.

### **15.8. Handlebar stops**

Solid stops (when on full-lock, other than steering dampers) must be fitted. These must ensure a minimum clearance of 30 [mm] between the handlebar with levers and the tank to prevent trapping the rider's fingers.

## **16. CONTROL LEVERS**

### **16.1. Handlebar control lever**

All handlebar levers (clutch, brake, etc.) must be in principle ball ended (diameter of this ball to be at least 16 [mm], see Figure 1). This ball can also be flattened, but in any case, the edges must be rounded (minimum thickness of this flattened part 14 [mm]). These ends must be permanently fixed and form an integral part of the lever. If the gear lever consists of a tube, then its edge must be rounded.

### **16.2. Control lever pivots**

Each control lever (hand and foot levers) must be mounted on an independent pivot.

### **16.3. Foot brake**

The brake lever if pivoted on the footrest axis must work under all circumstances, such as the footrest being bent or deformed.

### **16.4. Control levers modifications**

Hand- and foot-controls may be modified for mobility challenged riders.

## **17. THROTTLE CONTROLS**

Throttle controls must be self-closing when not held by the hand. The throttle operation (opening and closing) shall only be activated by mechanical cable from the twist grip directly attached to the throttle valve. Electronically controlled throttle valves are forbidden. All air intakes into the cylinder must pass through the throttle body. No other means allowing ambient air into the inlet track of the cylinder head are allowed.

## **18. IGNITION CUT-OUT SWITCH**

It is compulsory that all motorcycles be equipped with an operational cut-off switch, connected through a lanyard to the rider (max. length - 1m). Once the rider steps off the motorcycle, the lanyard must disconnect from the cut-off switch and cut the power to the engine.

In the case of vehicles belonging to Group J (Electric vehicles), refer to:

[https://www.fim-moto.com/en/documents?tx\\_solr%5Bq%5D=electric](https://www.fim-moto.com/en/documents?tx_solr%5Bq%5D=electric)

---

## Wheels

---

### 19. RIMS

Any modification to the rim or spokes of an integral wheel (cast, moulded, riveted) as supplied by the manufacturer, or of a traditional detachable rim other than for spokes, valve or security bolts, is prohibited.

The only exception is for tyre retention screws sometimes used to prevent tyre movement relative to the rim. If the rim is modified for these purposes, bolts, screws etc., must be fitted.

### 20. TYRES

A tolerance of +0.2 [mm] is applicable for all dimensions of Art. 20.1 to 20.5. The measurement of all tyres will be taken when they are mounted on the rim at a pressure of 1 [bar] (14,5 [psi]); measurements are taken at a tyre section plane with a 90° angle with the ground plane.

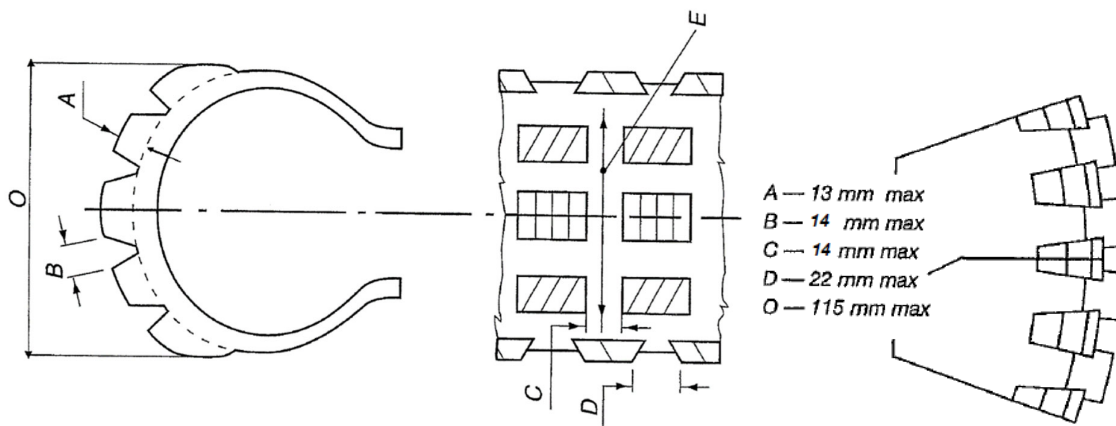

Figure 3 : Tyre dimensions

#### 20.1. Width

The overall width of the tyre when fitted must not exceed 115 [mm].

#### 20.2. Tread groove depth

The tread groove depth (A) must not exceed 13 [mm]. Such a depth shall be measured between the "minimum" of the tread groove and a line tangent with the top of the block. All blocks in the same circumference must be of the same depth.

#### 20.3. Space between blocks

The space between the blocks must not exceed 14 [mm] across the tyre (B) and 14 [mm] in a circumferential direction (C).

#### 20.4. Space between shoulder blocks

The space between shoulder blocks (D) must not exceed 22 [mm].

## 20.5. Space across the tread

The space across the tread (E) cannot extend completely across the tyre, measured at right angles to the wall of the tyre, unless broken by a block.

## 20.6. Tread blocks shape

All tread blocks (with the exception of the shoulder blocks) must be nominally rectangular with sides parallel with or at right angles to the tyre axis.

## 20.7. Type of tyres

Only tyres available from commercial or retail sources for use on the public highway are authorised.

They shall be approved according to UN Vehicle Regulation 75 Rev. 2 (2010) with the following specific features:

Category of use (5.2): it shall be "snow" or "special"

Speed category symbol (5.4): M (130 [Km/h]) or above

Load capacity index (5.5): 45 (165 [Kg]) or above.

The E (or the DOT) approval mark and number as defined by the UN Vehicle Regulation R75 must be present on both the front and rear tyre sidewalls.

Any marking on the tyre reporting "FIM" approved or similar is forbidden. FIM Quality Products are exempt of this rule.

## 20.8. Availability of tyres

The tyres shall appear in the tyre manufacturers range catalogue or tyre specification lists available to the general public.

## 20.9. Tyre restrictions

- 20.9.1. The tyres could be marked by the Technical Director or his/her team with the sole proposal to control the quantity of tyres used during the event.
- 20.9.2. The Technical Stewards may perform random controls during the event.

---

## Safety

---

## 21. OPEN TRANSMISSION GUARDS

A guard must be fitted to the countershaft sprocket in such a way that protection is provided for and covers both lower and upper chain runs. This aims at protecting from trapping fingers.

## 22. DRIVEN SPROCKET GUARDS

A chain guard must be fitted in such a way to prevent trapping between the lower chain run and the final driven sprocket at the rear wheel.

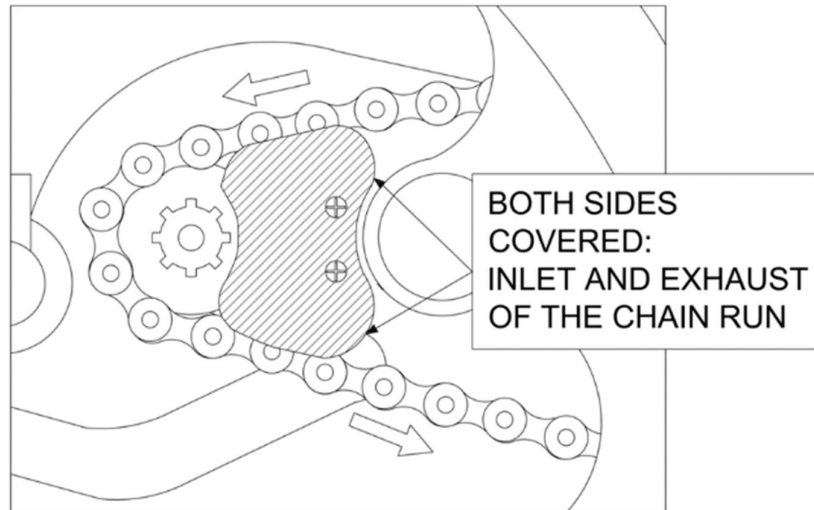

Figure 4 : Front sprocket protection

The external side of the rear sprocket must be completely covered by a hard, solid plastic sheet. No holes on the sprocket may remain visible.

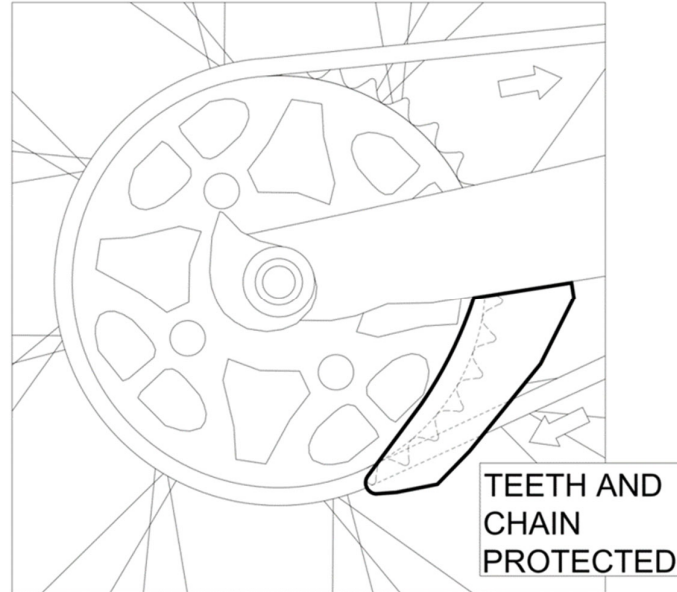

Figure 5 : Rear sprocket protection

## 23. EXHAUST PIPES AND SILENCERS

Exhaust pipes and silencers must fulfil all the requirements concerning sound control (see also FIM Sound Regulation).

### 23.1. Silencers position

The axis of the silencer end must be parallel (with tolerance of 15°) to the longitudinal plane of the vehicle and to the flat ground. The extremity of the silencer must not pass the vertical tangent of the rear tyre.

### 23.2. Silencer edge

The edge of the silencer shall not be dangerous in case of accidental contact with the riders or helpers. If the final tube protrudes more than 3 [mm], the edge must be rolled to an angle of 180° or radiused (see pictures below). In both cases, the edge thickness shall be 3 [mm] minimum.

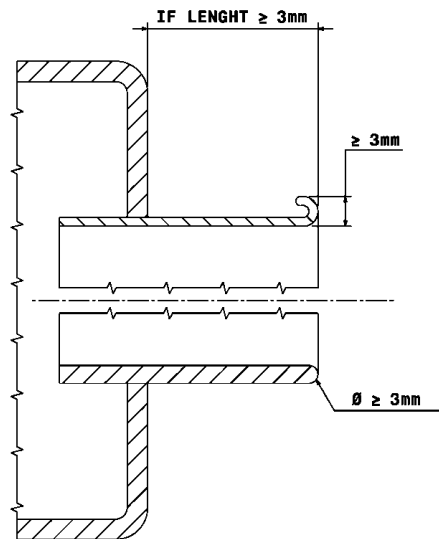

Figure 6 : Silencer edge

### 23.3. Exhaust fumes

Exhaust fumes must be discharged towards the rear but not in such a manner as to raise dust, foul the tyres or brakes, or any other rider.

## 24. FOOTRESTS

Footrests must be folding type and must come back automatically to the normal position after folding.

The footrest bracket must be solidly fixed to the motorcycle.

The footrest teeth shall not be sharp. The height of the footrest teeth must be 10 [mm] maximum. The end of the footrest must have at least 8 [mm] radius.

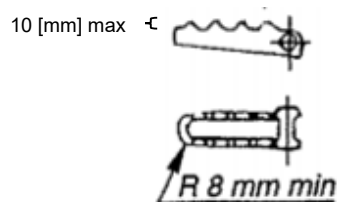

## 25. BRAKES

All motorcycles must have at least two efficient brakes (one on each wheel) operated independently and operating concentrically with the wheel.

Brake discs with sharp edges (saw tooth design) are forbidden.

### 25.1. Rear brake disk

The openings in the rear disk must be able to block a cylindrical gauge of 6 [mm] diameter. Brake disks with openings larger than 6 [mm] are allowed, but they must be covered by a rigid plastic protection and must also be compliant with Art. 25.2.

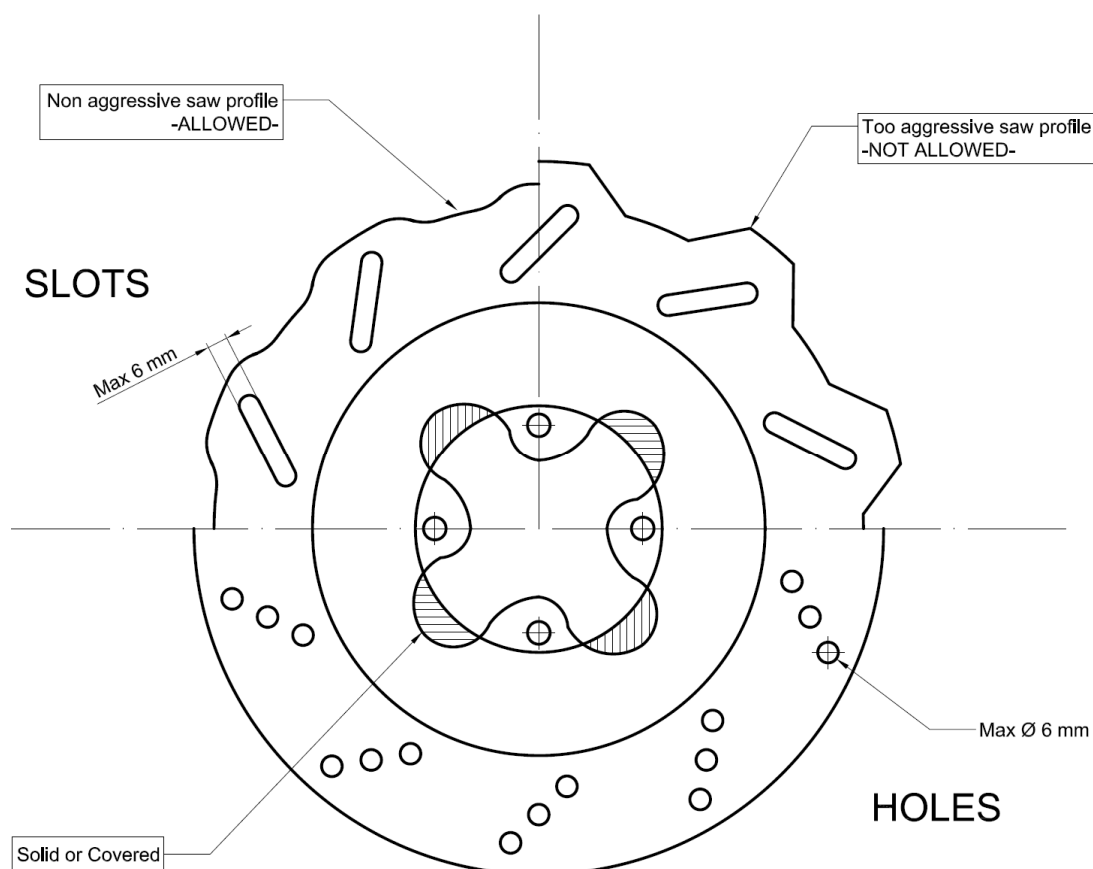

Figure 7 : Rear brake disk holes

### 25.2. Brakes protections

An external protection made from a rigid plastic material must cover the front and rear brake discs (fully in the front, partially on the rear or fully on the rear if the rear brake disk is not compliant with Art. 25.1). Holes for aeration and evacuation of materials must be able to block a cylindrical gauge up to 10 [mm] diameter.

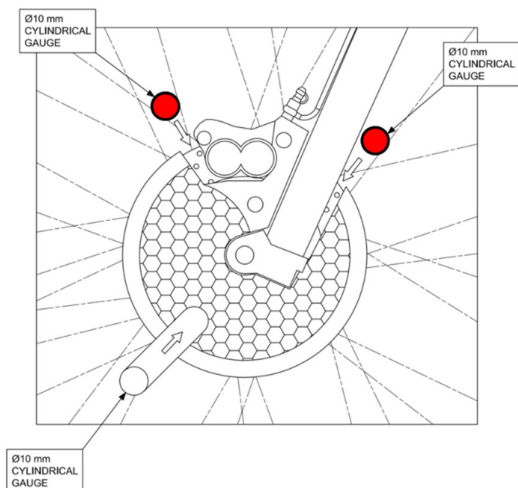

Figure 8 : Front brake disk protective cover

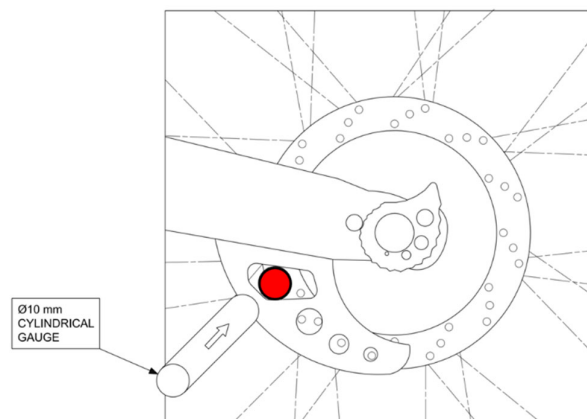

Figure 9 : Rear brake disk protective cover

## 26. MUDGUARDS AND WHEEL PROTECTION

Motorcycles must be fitted with front and rear mudguards.

### 26.1. Front mudguard

The front mudguard must cover at least 100° of the circumference of the wheel. The angle formed by one line drawn from the front edge of the mudguard to the centre of the wheel and one drawn horizontally through the centre of the wheel must be between 45 and 60°.

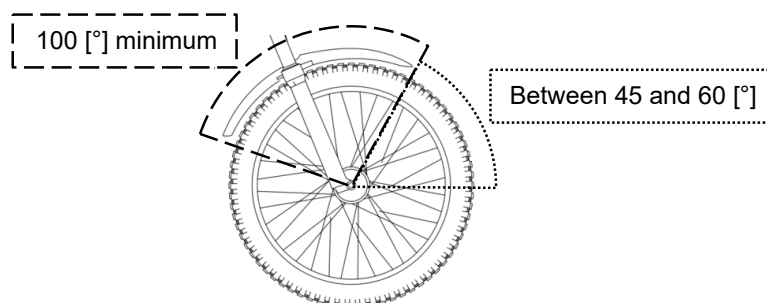

Figure 10 : Front mudguard position

### 26.2. Rear mudguard

The rear mudguard must cover at least 80° of the circumference of the wheel. The angle formed by two lines, one drawn from the rear edge of the mudguard to the centre of the wheel and one drawn horizontally through the centre of the wheel, shall not exceed 60°.

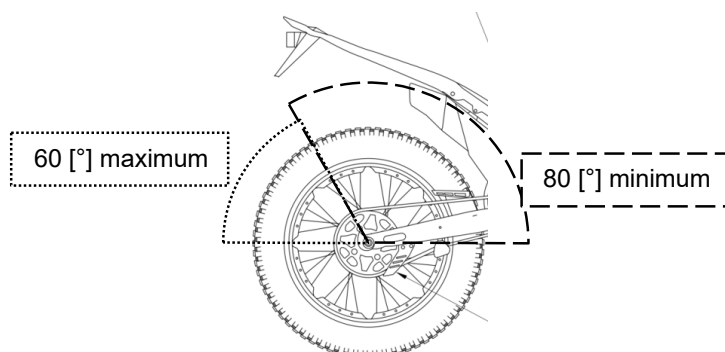

Figure 11 : Rear mudguard position

---

## Weight

---

### 27. MOTORCYCLE WEIGHTS

#### 27.1. Minimum weight

The weight (without rider and with all operational fluids) of the Trial motorcycles (thermal or electric engine) must not at any time be less than:

- For motorcycles racing in Trial3 (125cc equivalent): 67 [kg]
- For motorcycles racing in X-Trial, Trial2 or TrialGP class: 69 [kg]

These are absolute limits and no tolerance is applied when the machine is checked before the race. A 1% tolerance in the weight of the machine is accepted when checked during or after the event, in order to take into account the variability of the test conditions.

A scale with a minimum resolution of 100 [g] must be used.

A rider may be asked to submit his machine for a weight control in between laps or after the last lap.

#### 27.2. Ballast

The use of ballast to stay over the minimum weight is allowed, but it has to be properly fixed to the motorcycle. The term "ballast" refers to any component, device or part, whose primary function is to add weight to the machine. In case of a dispute, the decision of the FIM Technical Director will be final.

## D. RIDER'S EQUIPMENT

The FIM cannot be held liable for any injuries that a rider or passenger may sustain from the use of a specific item of equipment or protective clothing.



## 28. CLOTHING AND PROTECTORS

It is compulsory that riders, their Assistant and their Team Manager wear a suit or trousers, a long-sleeve shirt, a back protector and a knee protector.

It is recommended that all riders, their Assistant and their Team Manager wear chest and elbow protectors.

It is compulsory that all protective devices are clearly marked with the relative norms and comply with the following standard:

- EN 1621-1, Level 2, for shoulders, elbows, hips and knees
- EN 1621-2, Level 1 or 2, for the back protector: CB (Central Back) or FB (Full Back)
- EN 1621-3, Level 1 or 2, for the chest

Newer Labels (1621-2:2014)		
Full Back Level 1 or 2	<p>EN 1621 - 2: 2014</p>	<p>EN 1621 - 2: 2014</p>
	<p>EN 1621 - 2: 2014</p>	<p>EN 1621 - 2: 2014</p>
Older Labels (1621-2:2003)		
Full Back Level 1 or 2	<p>EN 1621 - 2</p>	<p>EN 1621 - 2</p>

**CHEST PROTECTOR: must comply with EN1621-3.**

EN 1621-3 Level 1 or 2	<p>EN 1621 - 3</p>	<p>EN 1621 - 3</p>
---------------------------	--------------------	--------------------

Repaired overalls are acceptable provided that the repair guarantees protection to the same standard as the original garment.

Any modifications brought to the protectors remove the certification of the equipment and will not be accepted.

If the clothing and/or protectors listed below does not meet the technical requirements or is found to be defective, the Technical Steward must clearly mark in red (e.g. with a red dot) all international marks without destroying them and retain it until the end of the event. The rider must submit another clothing and/or protectors for approval by the Technical Steward. After an accident involving impact, the back and chest protector must be presented to the Technical Steward for examination.

The Chief Technical Steward has the right to refuse any temporary repairs which are not deemed to provide the same protection as the original garment.

### **29. FOOTWEAR**

Footwear, in a good condition, made of leather or other materials having equivalent properties, shall be worn by riders, their Assistant and their Team Manager and have a minimum height of 30 [cm].

### **30. GLOVES**

Riders, their Assistant and their Team Manager shall wear gloves made of leather or other materials having equivalent properties.

### **31. EYE PROTECTION**

Riders, their Assistant and their Team Manager can wear goggles. The use of glasses, helmet visors and "roll offs" is also permitted. The material used for glasses, goggles and visors must be made of shatter-proof material. The use of "tear offs" is forbidden for environmental reasons. Helmet visors must not be an integral part of the helmet.

Eye protectors which cause visual disturbance (e.g. scratched) must not be used.

### **32. HELMET**

It is compulsory for all participants (including riders, their assistant and their Team Manager) taking part in practice and races to wear a protective helmet. The helmet must be properly fastened, be of a good fit, and be in good condition. The helmet must be correctly fastened at all time. Riders with long hair should tie it up in a bun, or braid and tuck it into their shirt or jacket.

For all participants using a helmet with a protective or non-protective chin guard, the chin guard shall not block the rider's vision. Moreover, only chin guards designed by the manufacturer for the helmet in question may be used.

### 32.1. Helmet type approval

All helmets must be marked with one of the official international standard marks mentioned below. Any FMN approval marks do not substitute the official international standard marks.

- FIM FRHP-he02
- EUROPE ECE R22-05 or ECE R22-06 (both “P” and “J”)
- JAPAN JIS T 8133:2015
- USA SNELL M 2015 or  
SNELL M2020R or SNELL M2020D or  
SNELL 2025R or SNELL 2025D

Attaching any object (such as camera, communication devices...) to the helmet, is forbidden, so the helmet won't be accepted.

Making any modification to the helmet is forbidden, so the helmet won't be accepted.

If a helmet does not meet the technical requirements or is found to be defective, the Technical Steward must clearly mark in red (e.g. with a red dot) all international marks without destroying them and retain the helmet until the end of the event. The rider must submit another helmet for approval by the Technical Steward. After an accident involving impact, the helmet must be presented to the Technical Steward for examination (see also Art. 40.4).

A helmet is made to provide protection. It is not a platform to attach foreign objects.

Examples of labels are reported below:

<b>FIM</b>	
<b>EUROPE</b>	

<p>JAPAN</p>	 <p>Protective helmet for motor vehicle users  <b>T8133:2015 Class 2</b>                  Certification No. XX0000000                  Label serial No. 0000000000                  Manufacturer's name                  (Trade mark of certification body)</p>
<p>USA</p>	

### 32.2. NATIONAL COLOURS FOR HELMETS

In competitions between national teams (e.g. FIM Trial of Nations), it is recommended that the helmet's overall graphics represent the colours of the team's national flag or the colours as mentioned in the table below. The national flag can be replicated in stripes, bands or other patterns.

Andorra	FMA	White with vertical blue, yellow and red bands
Argentina	CAMOD	White with blue horizontal band
Australia	MA	Green and yellow sides, red, white & blue representation of the Australian flag across the top
Austria	OeAMTC	Bright red with a 60 [mm] wide black band and the label of the OeAMTC in a white field on the front side
Belgium	FMB	Yellow
Brazil	CBM	Yellow and green
Bulgaria	BMF	Green and red
Canada	CMA	White and 3 Red Maple leaves, one on front and one on each side
Chile	FMC	Red with blue and white bands and white stars
China	CAMF	Red and yellow

Czech Republic	ACCR	Blue with red, white and blue border
Denmark	DMU	Red and white
Finland	SML	White with blue cross
France	FFM	Blue
Germany	DMSB	White with black border
Great Britain	ACU	Green
Greece	ELPA	White with blue border
Hungary	MAMS	Red and green
Ireland	MCUI	Green and orange
Italy	FMI	Red with one green and one white horizontal band
Japan	MFJ	White with red circle on top
Kenya	KMSF	Black, Red, Green, with white bands and the country name KENYA on both sides.
Luxembourg	MUL	Purple
Mexico	FMM	White with green and red border
Monaco	MCM	Blue and white
Netherlands	KNMV	Orange
New Zealand	MNZ	White with black kiwi on front
Norway	NMF	Red and blue
Peru	FPEM	Red with 75 [mm] wide white strips and blue and yellow chequered border
Poland	PZM	White with red band
Portugal	FNM	White
Rumania	FRM	Black with vertical blue, yellow and red bands with national emblem.
Russia	MFR	White with a red border and a vertical red band with star
San Marino	FSM	White with the San Marino National emblem
Slovakia	SMF	Blue, red and white
South Africa	MSA	Black, green, blue and red with yellow and white bands
Spain	RFME	Yellow and red
Sweden	SVEMO	Blue and yellow
Switzerland	FMS	Red with white cross
Uruguay	FUM	Light blue
USA	AMA	Blue with 2 white bands

In addition, the defending FIM Team World Champion is allowed to wear the rainbow colours on the helmet.

The rider's personal sponsors may be part of the overall graphics or displayed in a separate and dedicated area below the goggles strap (usually horizontal). The helmet model of each of the riders of a team may be different, but the graphics must have a similar visual appearance.

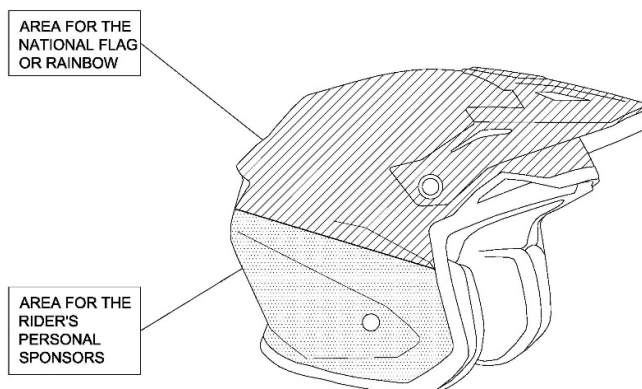

The overall graphics on the helmet must always be approved, in any case, by the FMN of the team.

Whenever a team is using a helmet and there is a case of *force majeure* (e.g. change of rider, broken helmet, etc.), the helmet in question can be replaced by any other helmet, provided that it complies with the FIM Technical Rules for the current year and has been presented to the Technical Stewards of the event.

## E. TECHNICAL VERIFICATION

### 33. PREPARATION

Before the START of the competition, a closed and guarded area shall be prepared.

Inspection must take place under cover with a large enough area.

Inspection area must be supplied with the necessary equipment, including tables, chairs, electric light and power outlet.

### 34. FMNR CHIEF TECHNICAL STEWARD AND TECHNICAL STEWARDS

The Chief Technical Steward must be in attendance at an event one hour before the Technical Verifications are due to begin. He must inform the Clerk of the Course/FIM Race Director and FIM Technical Director, if present, of his arrival.

The Chief Technical Steward must ensure that all technical stewards appointed for the event carry out their duties in a proper manner. The Chief Technical Steward shall appoint the technical stewards to individual posts for the race, practices and final control.

Scrutineers can have different tasks, but the team of scrutineers must have a minimum of three persons. The FMNR Chief Technical Steward must be a holder of an FIM SENIOR Technical Stewards Licence.

A minimum number of scrutineers is required according to the following:

- Checking of documentation: one
- Sound test, silencer marking: two
- Machine weight: one
- Machine inspection, helmet and clothing: two

The Sound Control Officer (SCO) must be holder of a valid FIM Technical Stewards' license, come with good knowledge and experience of the sound control and application of the test method. The FMNR may propose the services from a special technician (acoustic engineer) if there is no FIM licenced Technical Steward available to act as SCO.

The Chief Technical Steward must inform the Clerk of the Course/FIM Race Director of the results of the Technical Verifications. The Chief Technical Steward will then draw up a list of accepted machines and submit this list to the Clerk of the Course/FIM Race Director.

The Chief Technical Steward has the right to look/ inspect any part of the motorcycle at any time of the event.

All technical stewards shall be well informed and shall make sure their FMN has supplied them with all technical "updates" that may have been issued subsequent to the printing of the Technical Rules books.

### **35. FIM TECHNICAL DIRECTOR**

The FIM Technical Director is appointed by the Director of the FIM International Technical Commission in consultation with the Director of the FIM Trial Commission.

The FIM Technical Director is not responsible for the technical verifications but will ensure that they are carried out in accordance with the FIM Technical Rules.

The FIM Technical Director works in cooperation with the FIM Race Director and the FIM Delegate.

The authority and duties of the FIM Technical Director include but are not limited to (Please, also refer to the FIM Technical Rules):

The FIM Technical Director will report any concerns or deficiencies relating to the technical verifications to the FIM Race Director and FIM Delegate and present proposals to resolve such concerns.

The FIM Technical Director is the final arbiter in relation to technical issues at the event.

The FIM Technical Director will examine with the Chief Technical Steward the motorcycle(s) and the protective equipment of any rider(s) involved in serious or fatal accidents and present a written report to the FIM Delegate.

The FIM Technical Director will attend all meetings of the Race Direction, but without voting rights.

### **36. TECHNICAL VERIFICATION EQUIPMENT**

Weighing apparatus must be accurate, practical and have a minimum resolution of 100g. Weighing scales must have been certified by a National Institute within the period of 24 months before the event. Certified master weights and their certificate must be available for verifying.

The necessary tools are listed below:

- Revolution meter
- Sound meter, calibrator and spare batteries
- Slide calliper (for verifying engine capacity, carburettor diameter, etc.)
- Depth gauge
- Steel measuring tape
- Arrangement for measuring ground clearance (for Sidecars)
- Seals
- Weighing apparatus and set of reference weights (to be provided by the Promoter)
- Tools for measuring the engine capacity
- Lampoil tester is recommended and when used, it indicates the cylinder capacity. When a more precise measurement is required, the Chief Technical Steward may ask to take the cylinder head off the cylinder.
- Colour for marking parts
- Heat resistant stickers or paint for marking the silencer (and solvent)
- Magnet
- Adequate fuel sample bottles
- PC with CD Drive + updated operating system
- Printer, etc. are recommended
- Calculator

The necessary documents are listed below:

- Supplementary Regulations
- FIM Technical Rules - current year
- FIM Rules of the discipline concerned
- FIM Sporting Code
- Homologation papers (if applicable)
- Writing material
- Technical Verifications forms

All necessary measures and administrative equipment should be in place at least 1/2 hour before the start of the Technical Verifications is due to open (time in Supplementary Regulations).

### **37. BADGE OF THE FIM**

Under certain circumstances the FIM may permit the use of the FIM badge on certain equipment in order to show that the latter conforms to the standards laid down by the FIM. When this authorisation is granted and provided the equipment on which it appears is in good condition, the badge is then the guarantee of the conformity with the standard set by the FIM.



For the motorcycle control, a sticker or other piece of material (preference goes to plastics) must be fixed to the front of the main frame (and with preference on the same side of the frame on all the motorcycles).

### **38. PRESENCE AT THE TECHNICAL CONTROL**

The rider and/or the assistant and/or the Team Manager must attend at least once the Technical Verifications with the (rider's) machine within the time limits stated in the Supplementary Regulations.

The maximum number of persons present at the technical verification will be the rider and/or assistant and/or the Team Manager.

A rider remains at all times responsible that his machine and his personal protective gear are in conformity with the FIM Technical Rules for Trial motorcycles.

The rider and/or assistant and/or the Team Manager must present a clean motorcycle in conformity to the FIM rules.

The rider and/or assistant and/or the Team Manager must present one (1) motorcycle for the Individual Trial World Championship and up to two (2) motorcycles for the Indoor Trial World Championship.

The rider and/or assistant and/or the Team Manager must present the rider's protective wear (equipment), e.g. helmet and bib with prescribed starting number. The assistant's helmet must be presented too.

After the marking, riders must confirm his agreement by signing the Technical Verifications Form (Technical Card), which must indicate the frame number.

Competitors must retrieve their machines within the stipulated time by the Sporting regulations after the opening of the closed park area, except for the machines that are chosen for disassembly.

Any rider failing to report as required by the provisions below may be excluded from the meeting.

The Clerk of the Course/FIM Race Director may prohibit any person who does not comply with the rules, or any rider who could be a danger to other participants or to spectators, from taking part in the competitions.

### **39. MEASUREMENT OF CAPACITY**

#### **39.1. Reciprocating movement engine, "Otto" Cycle**

The capacity of each engine cylinder is calculated by the geometric formula which gives the volume of a cylinder; the diameter is represented by the bore, and the height by the space swept by the piston from its highest to lowest point:

$$\text{Capacity} = \frac{D^2 \times 3.1416 \times C}{4}$$

where D = bore  
and C = stroke

When a cylinder bore is not circular, the cross sectional area must be determined by a suitable geometrical method or calculation, then multiplied by the stroke to determine capacity.

When measuring, a tolerance of 1/10 [mm] is permitted in the bore. If with this tolerance the capacity limit is exceeded for the class in question, a further measurement should be taken with the engine cold, to 1/100 [mm] limits.

### 39.2. Rotary engines

The capacity of an engine which determines the class in which the motorcycle shall compete in a meeting shall be calculated by:

$$\text{Capacity} = \frac{2 \times V}{N}$$

where V = total capacity of all the chambers comprising the engine  
and N = number of turns of the motor necessary to complete one cycle in a chamber.

This engine is classified as a 4-stroke.

### 39.3. Wankel system

For Wankel system engines with a triangular piston, the capacity is given by the formula:

$$\text{Capacity} = 2 \times V \times D$$

where V = capacity of a single chamber  
and D = number of rotors

This engine is classified as a 4-stroke.

## 40. VERIFICATIONS

The Technical Verifications before the official practice should last at least 30 min, before the race last at least one hour, after the race last at least 30 min.

The Technical Verifications must be carried out in conformity with the procedure and times fixed in the CTR Rules and the Supplementary Regulations of the event.

The randomly based Sound control must be carried out first. The Sound level will be recorded in the Technical Verifications form. The exhaust silencer will be marked with paint.

An example of minimum verifications that shall be performed is given below:

- Sound (randomly based)<sup>1</sup>
- Make and model
- Cut-off switch
- Self-closing throttle
- Lights (front, rear, brake)<sup>2</sup>
- Race fuel certificate<sup>2</sup>
- Vehicle identification plate/chassis number
- Crankcase
- Wheels (hubs)
- Registration plate + insurance (green card)<sup>2</sup>
- Weight + ballast
- Silencer<sup>1</sup>
- Carburettor / Injection throttle body<sup>1</sup>
- Guard for the countershaft sprocket and rear sprocket
- Handlebar ends + protection + levers
- Front/rear brake disc protection
- Side stand<sup>2</sup>
- Tyres
- Helmet(s) + national colours<sup>2</sup>
- Protective clothing

An overall inspection of the motorcycle must be carried out in conformity with the FIM rules. Accepted motorcycles will be marked with paint or a sticker on frame and engine.

The Technical Verifications will be recorded on the Technical Verification form signed by the rider and/or his assistant and/or his Team Manager.

Non-marked motorcycle components can be changed at any time during the event except during Sections.

#### **40.1. Spare silencers**

The rider or the mechanic can present at the sound control, together with the vehicle, one (1) spare silencer to be checked.

Other spare silencers may be presented after all participants have presented their vehicles, or on the following days of the event.

---

<sup>1</sup> Except for electrical vehicles

<sup>2</sup> If applicable

## **40.2. Engine or frame damage**

In the case of inability to continue the event with the same marked frame and engine, the rider will have to state the technical reasons justifying the request for change to the Race Direction. The rider and/or his assistant, and/or his team manager can be asked to present the faulty frame and engine to the Chief Technical Steward or Technical Director who will decide on the unfixable character of the machine. The new frame or engine shall be presented to the Technical Verifications in order to be marked. This is not possible during Official Practice or during a Competition.

## **40.3. Exhaust silencer damage**

If an exhaust silencer is accidentally damaged, rendering the motorcycle excessively noisy, then the rider may replace the silencer but will have to keep and show the damaged silencer to the Chief Technical Steward or Technical Director at the completion of the lap. The new silencer shall also be presented in order to be marked (except if the already checked and marked spare silencer was used). Any motorcycle which has had the exhaust silencer replaced (except if the already checked and marked spare silencer was used) will be subject to a sound level control at the final control.

## **40.4. Helmet control**

Scrutineers, under the supervision of the Chief Technical Steward, may check prior to practice and the races that all helmets meet the technical requirements.

If a helmet does not meet the technical requirements or is found to be defective, the Technical Steward must clearly mark in red (e.g. with a red dot) all international marks without destroying them and retain the helmet until the end of the event. The rider must submit another helmet for approval by the Technical Steward. After an accident involving impact, the helmet must be presented to the Technical Steward for examination.

### **40.4.3. Helmet good fit condition**

The Chief Technical Steward/Technical Steward may ask a rider for the following checks before the rider is permitted to take part in practice of the race:

- That the helmet fits well on the rider's head.
- That it is not possible to slip the retention system over the chin, when fully fastened.
- That it is not possible to pull the helmet over the rider's head by pulling it from the back of the helmet.

## **41. DECISION**

Action and decisions will depend on the Sporting Discipline concerned, and decisions taken during prior discussions with the FIM Technical Director and/or the Chief Technical Steward.

## 42. FINAL EXAMINATION

In a competition which requires a final examination of machines before the results are announced, this examination must include a sound control measurement of at least three machines chosen at the discretion of the Clerk of the Course/FIM Race Director in co-operation with the Chief Technical Steward. Refer to each discipline for more info.

## F. ADDITIONAL SPECIFICATIONS FOR ELECTRIC POWERED VEHICLES (EPVS, GROUP J)

See also “FIM ELECTRIC REGULATION”

[https://www.fim-moto.com/en/documents?tx\\_solr%5Bq%5D=electric](https://www.fim-moto.com/en/documents?tx_solr%5Bq%5D=electric)

## 43. EPV INTRODUCTION

### 43.1. Power bus maximum voltage

Class “A”: Following the safety regulation Class A, the maximum allowed voltage in the main power bus is 60VDC (and 30VAC (rms)) (pulsory DC < 60V). A secondary power bus may be used to supply energy to the critical systems at a maximum voltage of 20VDC or 14VAC (replaced by 60 V DC or 30 V AC – pulsory DC <60V).

Class “B”: The maximum allowed voltage in the main power bus is 420 V DC or 300 V AC (rms). A secondary power bus may be used to supply energy to the critical systems at a maximum voltage of 20VDC or 14VAC (replaced by 60 V DC or 30 V AC – pulsory DC <60V).

## G. ADDITIONAL SPECIFICATIONS FOR TRIAL VINTAGE MOTORCYCLES

## 44. TVM INTRODUCTION

All motorcycles must meet the current safety standards in force whatever their nature and their modifications on standard, authentic or prototype Vintage motorcycle.

Definition of a FIM Trial Vintage Motorcycle for the “FIM Trial Vintage Trophy”:

Standard Motorcycle or Motorcycle having participated in its time and having the following characteristics:

- Twinshocks (monoshock Motorcycles converted into twinshocks are not accepted)
- Air Cooled
- Drum brakes

In addition:

- Maximum 36mm diameter of front fork; Except “SWM 350 Jumbo” and “MERLIN Cagiva DG 350” with (38 mm)
- No hydraulic Clutch

Definition of a Trial Motorcycle for the “FIM Trial Motorcycle Vintage Trophy”:

For Original Motorcycles only!

Reserved for Motorcycles in their original production form, or period works prepared.

Prototypes are authorized if their authenticity and their participation in Events "in their time" are proven and/or validated by Experts and officials of the FIM.

All the Aesthetic aspects and the technical parts of the motorcycle must be respected, the structure, choices and qualities of the original/ production constructions.

Prototypes or “non-original” parts could be accepted if these have been authenticated and certified as riding "at their time".

Any recent reconstruction, even executed in "the rules of the art" may be refused.

Aesthetic aspect means: shape, materials, colour, quality of conservation and/or reconstruction.

Some exceptions can be granted, declared and verified during Technical inspections:

- Any accessory imposed by the Technical and safety rules of the present regulations.
- As for example: Padded handlebars; Engine stopping system; Front & Rear sprocket/chain protection; Rear sprocket with hidden holes, etc...
- The Tyres
- The electronic ignition system, if it has no visual aspect.

## **H. SOUND CONTROL**

Exhaust pipes and silencers must fulfil all the requirements concerning sound control (see also FIM Sound Regulation). Please refer to:

[https://www.fim-moto.com/en/documents?tx\\_solr%5Bq%5D=sound](https://www.fim-moto.com/en/documents?tx_solr%5Bq%5D=sound)

## **I. FUEL REGULATIONS**

Please refer to FIM Fuel Regulations:

[https://www.fim-moto.com/en/documents?tx\\_solr%5Bq%5D=fuel](https://www.fim-moto.com/en/documents?tx_solr%5Bq%5D=fuel)

## **J. DIAGRAMS**

# CHECKLIST

1. Sound test (if applicable)
2. Cut-off switch + self-closing throttle control
3. Make + model + fuel
4. Vehicle identification plate and chassis number
5. Registration plate (if applicable)
6. Weight + ballast
7. Fuel tank (if applicable)
8. Guard for the countershaft sprocket and rear sprocket
9. Handlebar protection
10. Front/rear disc brake protection (if applicable)
11. Helmet + national colours (if applicable)

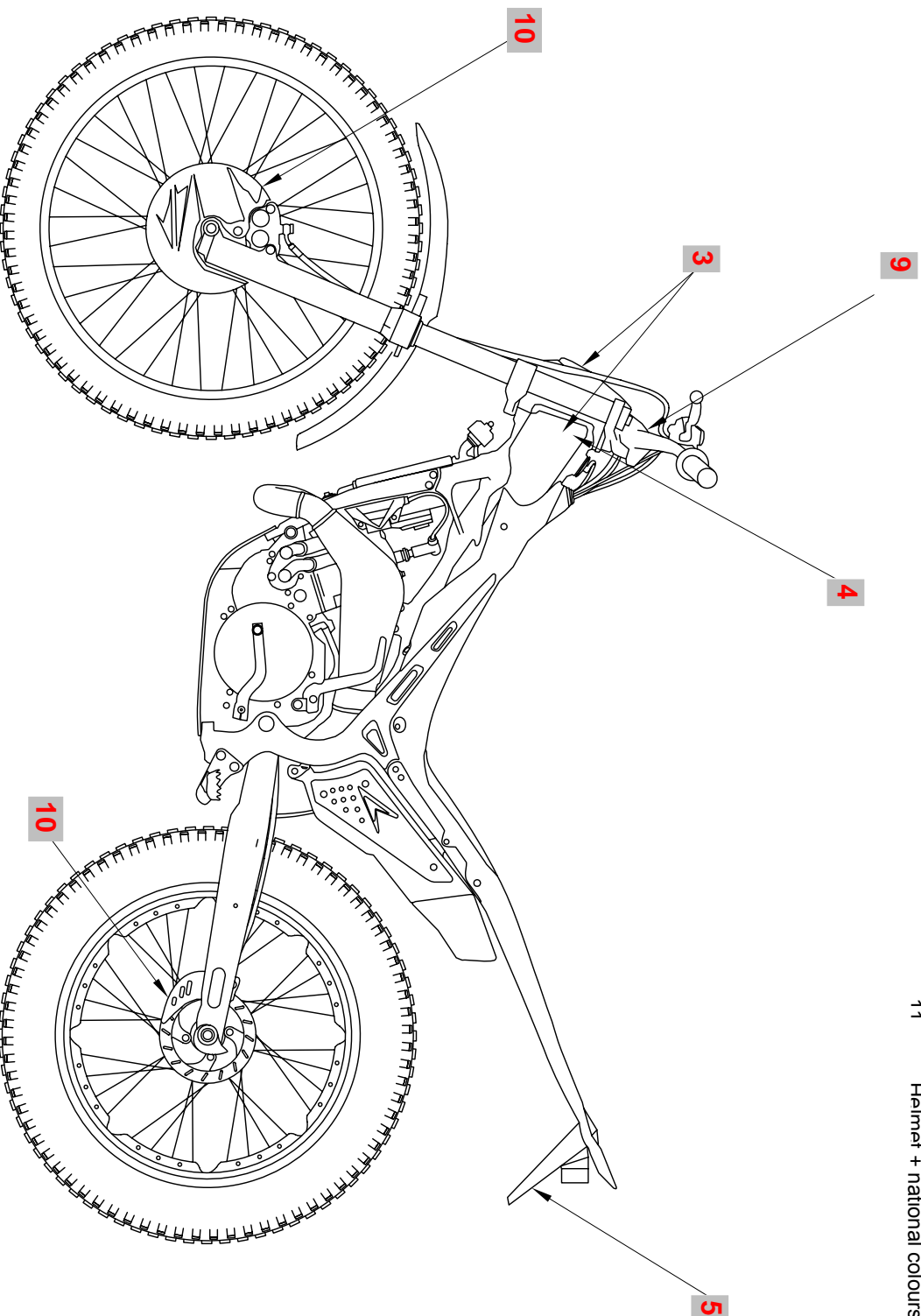



# CHECKLIST

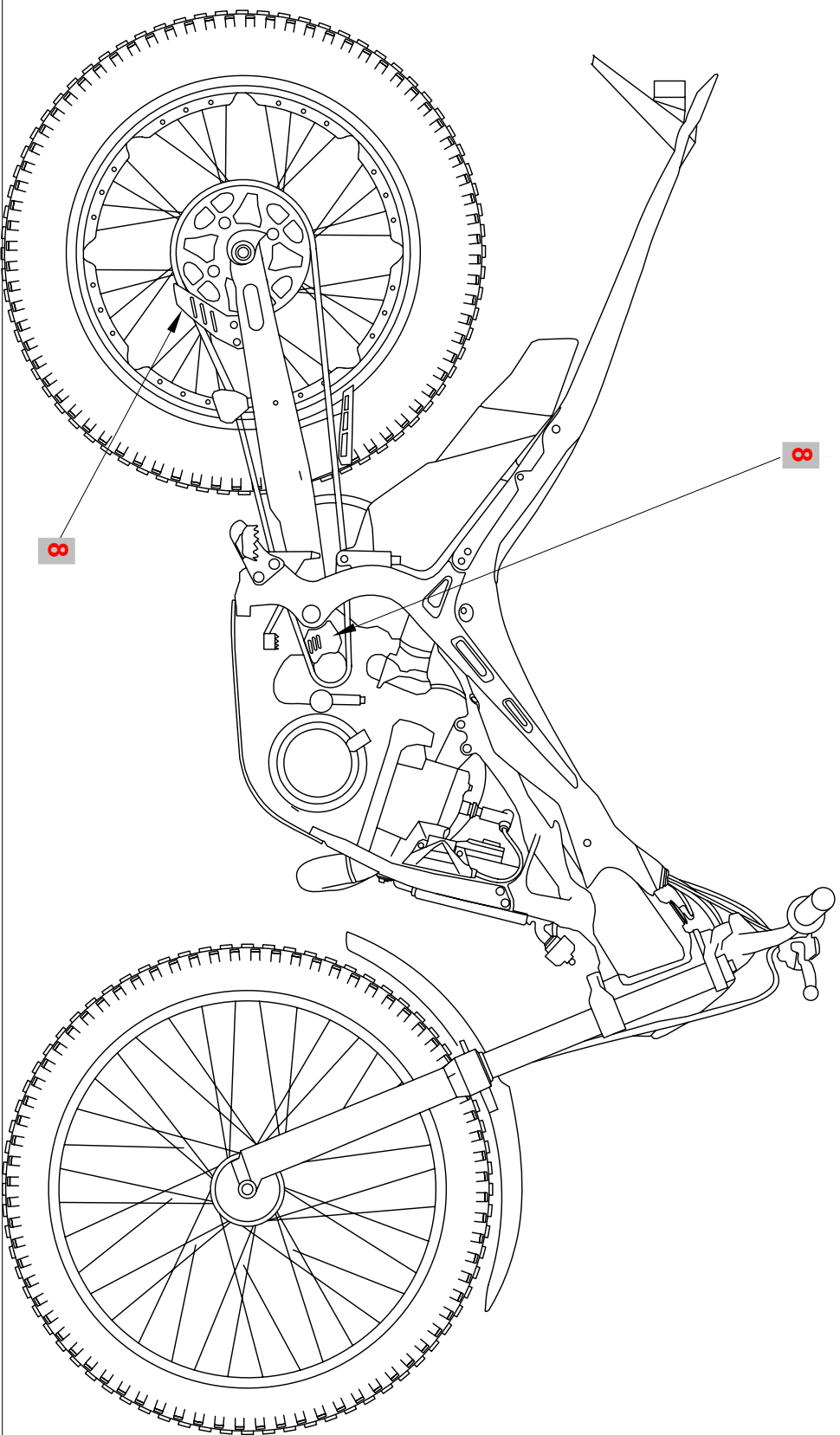

D

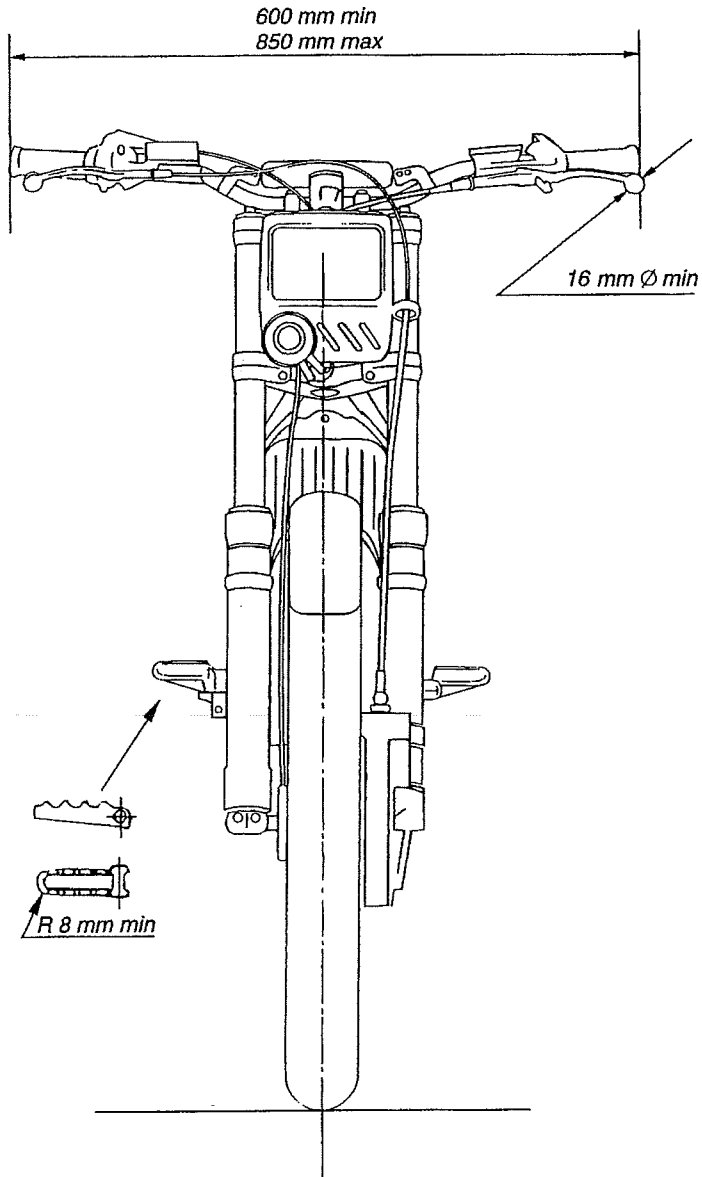

## **TEN FITTING TESTS FOR HELMETS** **DIX TESTS D'ADAPTATION POUR LES CASQUES**

1. *Obtain correct size by measuring the crown of the head*  
Avoir la bonne grandeur en mesurant le sommet de la tête
2. *Check there is no side to side movement*  
Vérifier qu'il n'y ait pas de déplacement d'un côté à l'autre
3. *Tighten strap securely*  
Serrer solidement la jugulaire
4. *With head forward, attempt to pull up back of helmet to ensure helmet cannot be removed this way*  
Tête en avant, essayer de soulever le casque pour s'assurer qu'il ne peut pas être enlevé de cette façon



5. *Check ability to see clearly over shoulder*  
Vérifier si vous pouvez voir clairement par-dessus l'épaule
6. *Make sure nothing impedes your breathing in the helmet and never cover your nose or mouth*  
S'assurer que rien ne gêne votre respiration dans le casque et ne jamais couvrir le nez ou la bouche
7. *Never wind scarf around neck so that air is stopped from entering the helmet. Never wear scarf under the retention strap*  
Ne jamais enrouler une écharpe autour du cou, car cela empêche l'air d'entrer dans le casque. Ne jamais porter d'écharpe sous la jugulaire
8. *Ensure that visor can be opened with one gloved hand*  
S'assurer que la visière peut être ouverte avec une main gantée
9. *Satisfy yourself that the back of your helmet is designed to protect your neck*  
S'assurer que l'arrière de votre casque a une forme telle qu'il vous protège la nuque
10. *Always buy the best you can afford*  
Toujours acheter le meilleur que vous pouvez vous offrir



**FEDERATION INTERNATIONALE  
DE MOTOCYCLISME**

**FIM-MOTO.COM**

ROUTE DE SUISSE 11 | 1295 MIES | SWITZERLAND

cti@fim.ch

6579003



FEDERATION INTERNATIONALE  
DE MOTOCYCLISME

FIM SOUND  
REGULATIONS

2025

# FIM Sound Regulations

## *Règlement FIM pour le son*

Modifications log		
Updated	Applicable as from	Modified articles
0	01.01.2025	D; E
<b>1</b>	<b>09.01.2025</b>	<b>E</b>
<b>2</b>	<b>11.02.2025</b>	<b>E</b>

Articles amended as from 01.01.2025 are in bold type  
Articles amended during the 2025 season are in bold and **red type** or **strike**

---

## Table of Contents

A.	INTRODUCTION.....	3
B.	PREPARATION OF THE SOUND METER.....	4
C.	SET UP OF THE MEASUREMENT .....	4
D.	TEST PROCEDURE .....	9
E.	SOUND LIMITS.....	13
1.	TRIAL World Championships, Cups and Prizes.....	14
2.	TRACK RACING World Championships, Cups and Prizes.....	14
3.	ENDURO, SUPERENDURO, HARDENDURO World Championships, Cups and Prizes.....	14
4.	SAND RACES World Championships, Cups and Prizes.....	14
5.	CROSS-COUNTRY RALLIES & BAJAS World Championships and Cups 15	
6.	MOTOCROSS World Championships, Cups and Prizes .....	15

## A. INTRODUCTION

In order to pursue the measures taken to reduce the sound level in favour of environment and in the framework of the 'RIDE QUIET' campaign, a new method for measuring the sound level called "2 metre max" is applied as from 2013 in all 'all-terrain' disciplines.

For the first World Championship event, all competitors' motorcycles will be checked for sound level. After the first event, the motorcycles of a 'wild card-' or 'one event' rider, will be checked for the sound level, as well as any other rider's motorcycle on a random basis.

Excessively loud motorcycles must always be checked, regardless of the participants' status.

The technical specifications and the resources to apply such a method, for the use of the technical stewards and officials, are outlined in the present article.

The "2 metre max" method shows a very good correlation between the sound power level (LWA) issued by motorcycles in full acceleration, and the maximum sound pressure levels measured at proximity of the same motorcycles, with engines at idle and quickly taken to their maximum rotational speeds.

The "2 metre max" method will consist in quantifying not only the sound level produced by the silencer of the exhaust, but the maximum global sound level achieved by the motorcycle when the engine rpm's are raised to the maximum engine speed, limited by a natural regulation (for 2 strokes) or rev limiters (for 4 strokes).

Only the sound levels measured with the "2 meter max" method will be considered by the technical stewards and by the Race Direction/Jury of the event to decide whether the motorcycle is in conformity with the maximum sound levels authorised.

For Motocross disciplines, Enduro/SuperEnduro/HardEnduro, Sand Races, Cross-Country Rallies and Bajas:

Before the opening of the season, the manufacturers must declare to the FIM International Technical Commission (CTI) at [cti@fim.ch](mailto:cti@fim.ch) the maximum power rpm value of the engine of their motorcycles (in standard 'production' specification as sold on the market). The minimum threshold of rpm applied for each class for the sound control procedure will be defined and communicated by the FIM Technical Director.

No modification (in any possible way) of the original RPM channel is allowed. During the sound control, the engine must be able to reach its maximum admissible RPM level (meaning at least the minimum rpm set for each class by the FIM Technical Director according to the information provided by the manufacturers) in Neutral or In Gear position of the gearbox (at the discretion of the Sound Control Officer (SCO)).

The motorcycles fitted with ECU map select switches, all switch positions may be tested.



Furthermore, all systems of dB-Killers must be either the original part delivered by the exhaust manufacturer or made in a safe and professional (well-engineered) way. In case of dispute, the decision of the FIM Technical Director will be final.

## B. PREPARATION OF THE SOUND METER

For all FIM championships and prizes, sound level meters must conform to the frequency response tolerance for Class 1 or Class 2 for nominal frequencies between 125Hz to 8000Hz, as stated by the IEC 61672-1:2013 subsection 5.5 standard.

All sound level meters must also conform to the tolerance for Class 1 or Class 2 for amplitude linearity, for its specified class, as stated by the IEC 61672-1:2013 subsection 5.6 standard. IEC 61672 is a regulatory document, which covers specifications and qualification requirements for class 1 and class 2 sound level meters.

Two sets of equipment must be available in case of failure of tachometer, sound level meter or calibrator during technical control.

Sound level measuring equipment must also include:

- a compatible calibrator, which must be used immediately before testing begins and always just prior to a re-test if a disciplinary sanction may be imposed;
- a tachometer.

The sound meter shall be prepared by applying the following procedure:

1. Activate the 'A' weighing
2. FAST time weighting must be activated
3. Select the highest range available (ex. 80~130 [dB])
4. Calibrate the sound meter according to the instructions, taking into account the incidence of the wind foam ball
5. Position the wind foam ball on the microphone
6. Activate the function MAX MIN – set on MAX

## C. SET UP OF THE MEASUREMENT

The sound levels will be measured with the microphone fixed on a tripod at a height of 1.35 m above the ground, in horizontal (levelled) position. It is helpful to have the microphone equipped with an extension cable to the sound meter.

For the place and position of the motorcycle, ensure that there are no solid obstacles within 10 m around the microphone.

Depending on the vehicle, the sound meter will be positioned:

**for Solo motorcycles:** at an angle of 45° from the longitudinal axis of the vehicle, on the exhaust side, at a distance of 2 m behind the vehicle (measured from the point where the centre of rear tyre touches the ground).

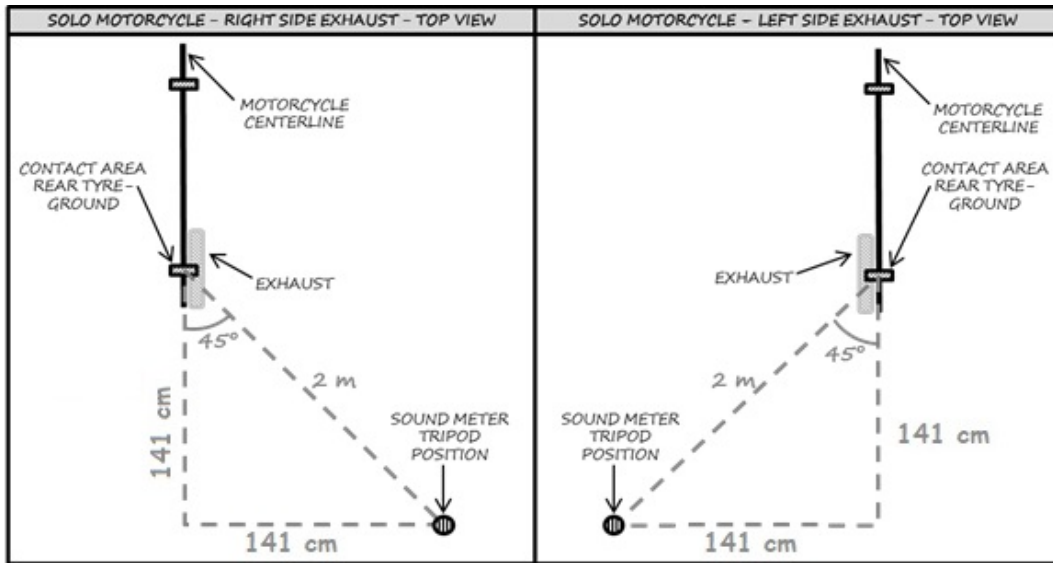

Figure 1 : Sound meter position for solo motorcycle

**for Solo motorcycles with 2 exhaust outputs:** at an angle of 45° from the longitudinal axis of the vehicle, on the side of the air intake, at a distance of 2 m behind the vehicle (measured from the point where the centre of rear tyre touches the ground). Note: if a central positioned air intake is used, both sides will be tested.

**for Snowmobiles:** at an angle of 90° from the longitudinal axis of the vehicle, on the side of the silencer, at a distance of 2 m next to the vehicle (measured from the silencer exit). For continuity of the measurement, use the handlebar as a reference to line up the motorcycle with the microphone - the exhaust pipe is usually located on the right hand side of the motorcycle and directly under the handlebar position. Note: the use of only one silencer is allowed for Snowmobiles.

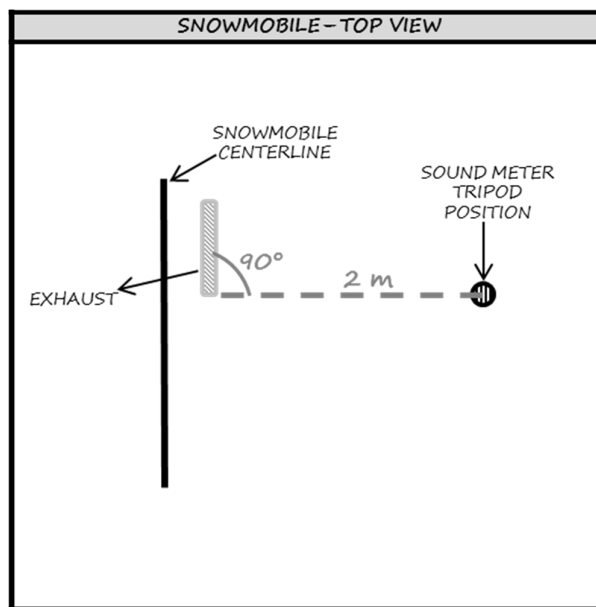

Figure 2: Sound meter position for solo snowmobile

**for Sidecars:** at an angle of 45° from the longitudinal axis of the vehicle, on the sidecar side, at a distance of 2 m behind the vehicle (measured from the point where the sidecar tyre touches the ground). If the exit of the silencer is closer to the motorcycle rear wheel, the reference point will be the contact point of the motorcycle rear wheel on the ground (as for Solo motorcycles).

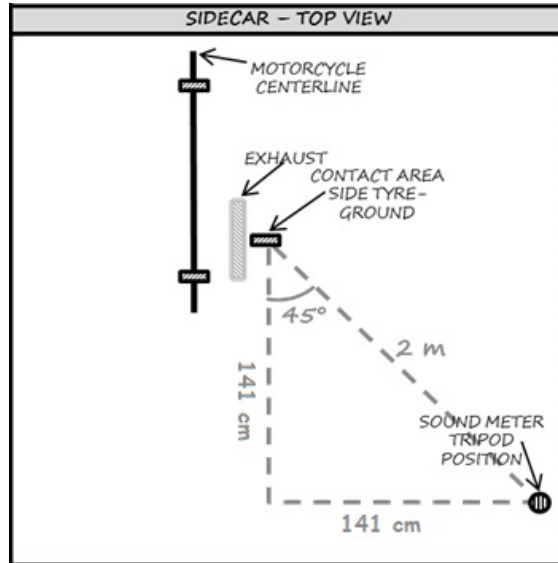

Figure 3: Sound meter position for sidecars

**for Quads:** at an angle of 45° from the median longitudinal axis of the vehicle, at a distance of 2 m behind the vehicle (measured from the point where the line drawn perpendicular to the rear axle touches the ground).

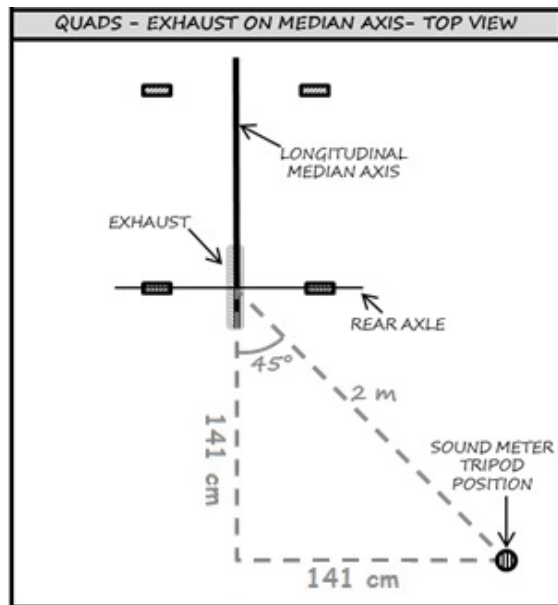

Figure 4: Sound meter position for quads

**for Quads with the exhaust moved out of the median axis:** at an angle of  $45^\circ$  from the rear axle, from where the rear axle and the exhaust meet, at a distance of 2 m behind the vehicle (measured from the point where the line drawn perpendicular to the rear axle touches the ground).

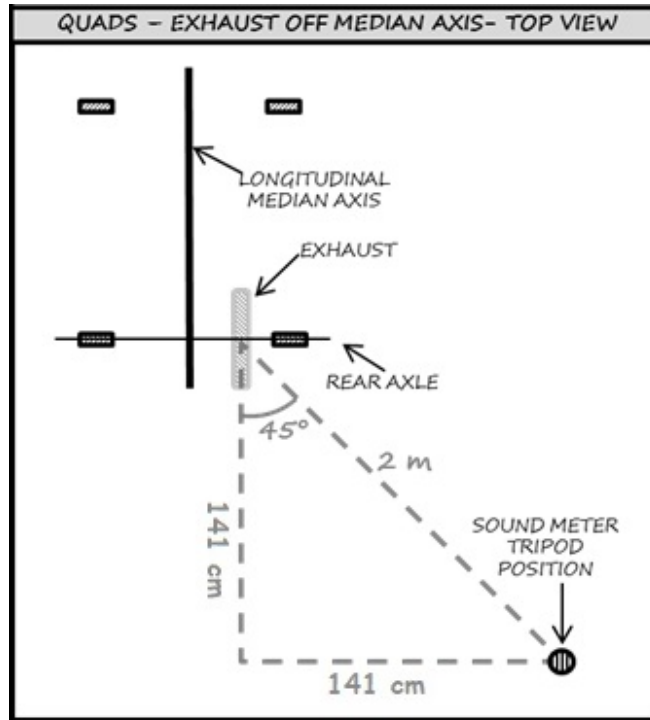

Figure 5: Sound meter position for solo motorcycle with exhaust moved out of the median axis

The sound level for engines with more than one silencer will be measured on each exhaust end.

Silencers fitted with adapters aiming to reduce the sound level shall be permanently fitted.

To make repetitive measurements, all motorcycles can be positioned into a small frame fixed on the ground, making sure to respect the  $45^\circ$  requirements. A squared frame helps the positioning of the motorcycle.

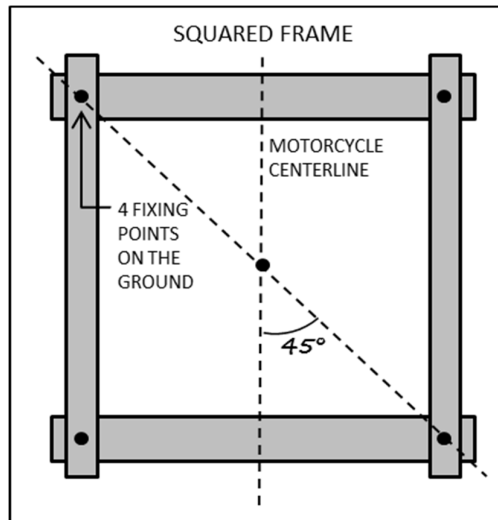

Figure 6 : Squared frame design

Vehicles which are not equipped with a gear box neutral must be placed on a stand.

It is preferred to make the tests on soft ground, not reverberating, i.e. grass or fine gravel.

In other than moderate wind, motorcycles should face forward against the wind direction.

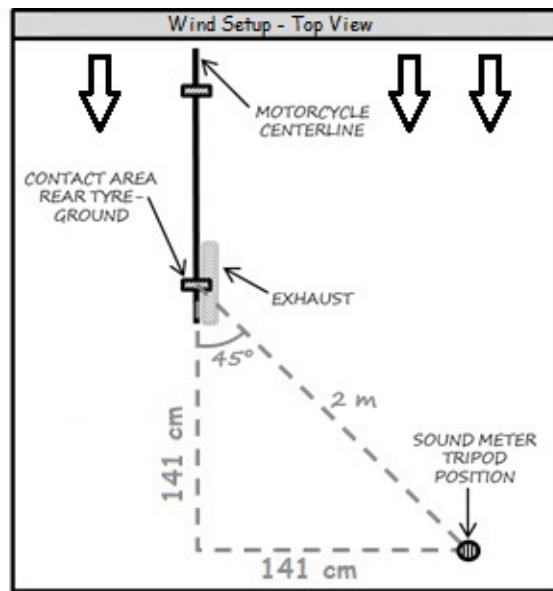

Figure 7 : Setup during windy conditions

The ambient sound at the point of measurement must be minimum 15 [dB/A] less than the lowest FIM sound limit applied in each discipline.

It is recommended to re-calibrate the sound meter before starting measurements and before putting the system away except when there has been any accident (physical impact to the equipment). In the event of an impact, the sound meter must be systematically re-calibrated before restarting any measurements.

## D. TEST PROCEDURE

The Sound Control Officer (SCO) must be holder of a valid FIM Technical Stewards' license, come with good knowledge and experience of the sound control and application of the test method. The FMNR may propose the services from a special technician (acoustic engineer) if there is no FIM licenced Technical Steward available to act as SCO.

The SCO must have arrived in sufficient time for discussions with the Clerk of the Course/FIM Race Director and other Technical Officials in order that a suitable test site and testing procedure can be agreed.

The SCO (identified as "SCO" on the drawing here under) must be positioned on the right side of the vehicle, between the handlebar and the footrest, managing the throttle grip during the whole sound control procedure. During the sound control procedure, nobody can stand in the grey "prohibited" area between the muffler and the microphone area defined by the following drawing:

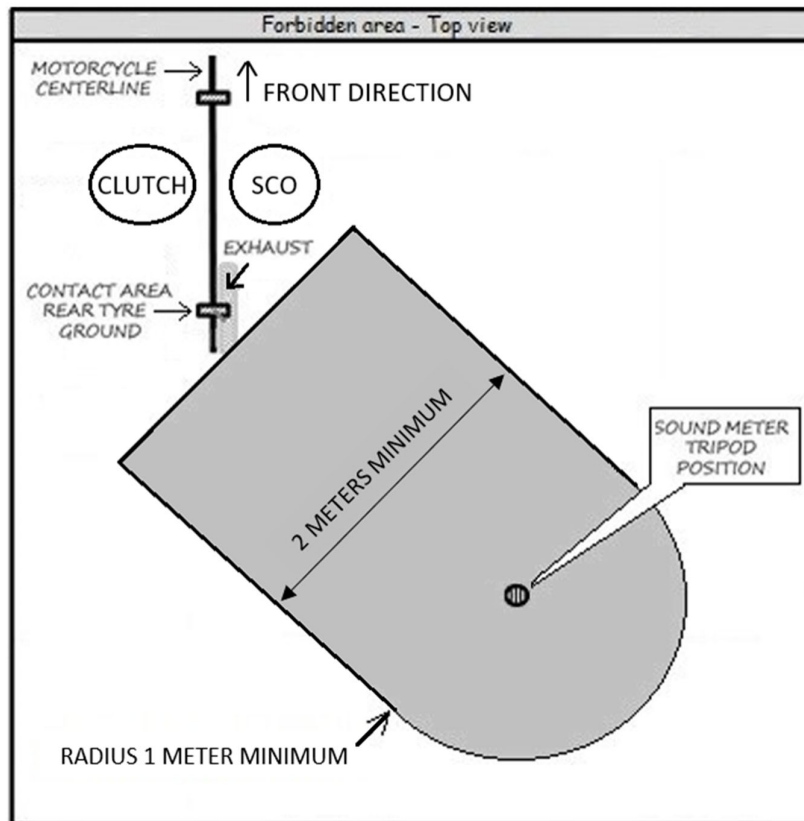

Figure 8 : Prohibited area during the Sound Control

A second technical steward can be present to help. The rider can also be present.

It is strongly advised that the technical steward(s) use earplugs, a headset or ear protectors.

The measurements are made with motorcycle on its wheels, with a hot engine, whatever in neutral gear position or in-gear position (at the discretion of the SCO).

During the sound test, only the rider may sit on the vehicle in the normal riding position (at the discretion/decision of the SCO). For safety reasons, we recommend to the SCO to always keep the rear brake pedal under pressure during the sound control procedure.

The CLUTCH: a rider, a mechanic (or a second FIM/FMNR technical steward where compulsory (example: MXGP)) identified as "CLUTCH" on the drawing here above, positioned on the left side of the vehicle, between the handlebar and the footrest, shall disengage the clutch during the whole sound control procedure.

The SCO (and not others) shall open the throttle as fast as possible (instantly, within 0.3 s) until "full open throttle", in order to reach the maximum rpm value ("max. rpm").

**For Motocross, Enduro/SuperEnduro/HardEnduro, Cross-country rallies/Bajas, Sand Races and Track Racing motorcycles with no FIM homologated silencers,** the "max rpm" is the one defined by the ECU (for 4-stroke engines), or by a natural regulation (for 2-stroke engines).

When in doubt, it can be verified that such "max. rpm" value is higher than the rpm value at which the vehicle supplies its maximum power (kW) ("max. power rpm").

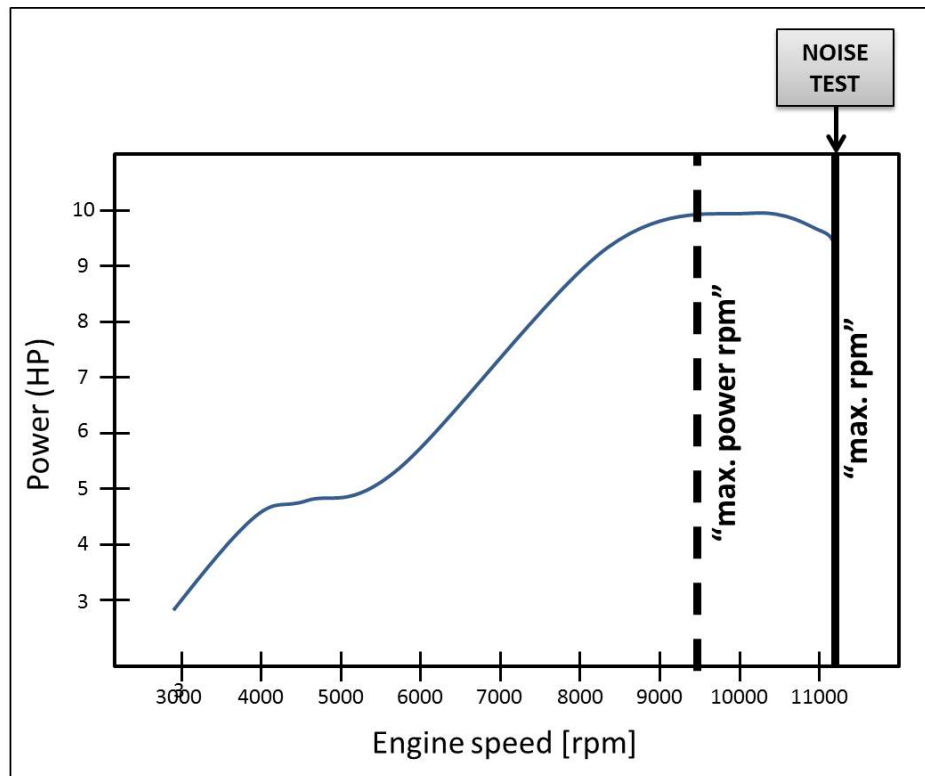

**For Trial,** the "max rpm" is established at 10000 ( $\pm 200$ ) rpm and obtained thanks to a dedicated "sound test" mapping of the internal ECU or an external one, purpose-made and connected in occasion of the test.

**For Track-Racing with FIM homologated silencers,** when sound tests are needed, the "max rpm" is established at 11000 ( $\pm 500$ ) rpm.

The SCO then keeps the engine at the "max. rpm" value for at least 1 s (or until there is an audible sign of over-revving the engine), during which the measurement is taken.

To conclude the test, the SCO releases the throttle quickly.

The maximum noise value (dB/A) registered during the measurement interval is then read on the sound meter and recorded. This noise value shall not be rounded down to the nearest whole number.

The noise value is then compared with the sound limits (see **Art. E**).

The noise test can be "**PASSED**" or "**NOT PASSED**":

**"PASSED"**: The sound test is considered "passed" if the recorded noise value is below or equal to the sound limits of **Art. E**. The silencer can then be marked by the SCO at the end of the test.

The silencer can be changed after verification under the conditions of Technical control.

The end opening of the silencer shall remain unmodified once it has been checked and marked.

**"NOT PASSED"**: The sound test is considered "not passed" if the recorded noise value is above the sound limits of **Art. E**.

In this case, the vehicle (with the same silencer) can be presented again, but for two more tests maximum. If the third test result is negative, the rider can present a different or repaired silencer (in case the sound test was done before the race) will receive a penalty (in case the sound test was done during or after the race).

The sound meter is then reset by pushing on the side-line and armed by pushing on the side-line again.

Sound controls during the event or after the race:

- the motorcycle must be tested in the exact conditions at any time of the event when the FIM Technical Director requests the team/rider for a sound control.
- the motorcycle must be tested in the conditions it has finished the race and has rejoined the parc fermé.

**Notes:**

If the engine starts to misfire, close the throttle slightly and re-open the throttle. If detonations appear, the measurement must be started again.

For vehicles without an engine rev. limiter, the throttle will have to be opened not more than 2 s or until there is an audible sign of over-revving the engine.

Even in case a vehicle has not exceeded the respective sound limit, if there is any doubt, the vehicle may be checked again.



If the vehicle is unable to reach the "max. power rpm" value, the vehicle shall be refused. Any attempt by a participant to prevent his engine from reaching the "max. power rpm" will be considered a breach of the rules.

In case the SCO doubts that the "max. power rpm" value (as declared by the manufacturers or previously obtained with the dyno test), he/she shall measure the engine speed with a tachometer connected to the spark.

The motorcycle must maintain at least the minimum RPM during the sound controls. Any motorcycle that is unable to reach and maintain the minimum RPM stated will be refused (applicable with the Race Patrol (/Lite) sound meter from EA LAB (or any other RPM readers)). In case of dispute, the decision of the FIM Technical Director will be final:

<b>Minimum RPM thresholds</b>		
<b>Motocross, Supermoto &amp; RallyGP</b>		
50 cc 65 cc	2T	11500 rpm
65 cc to 85 cc		11500 rpm
100 cc to 125 cc		11000 rpm
175 cc to 300 cc		9000 rpm
85 cc to 150 cc	4T	13500 rpm
175 cc to 250 cc		13500 rpm
290 cc to 350 cc		12000 rpm
450 cc		10800 rpm
<b>Sidecar Motocross</b>		
	2T	<b>8000 rpm</b>
	4T	<b>9000 rpm</b>
<b>Snowcross Motocross</b>		
	2T	<b>8000 rpm</b>
	4T	<b>TBC rpm</b>
<b>Quads Motocross</b>		
<b>up to 500 cc</b>	2T	<b>9000 rpm</b>
<b>up to 450 cc</b>	4T	<b>10400 rpm</b>
<b>451 - 500 cc</b>	4T	<b>9000 rpm</b>
<b>Enduro. Rally 2, Rally 3</b>		
up to 125 cc	2T	11000 rpm
Over 125 cc		9000 rpm
up to 250 cc	4T	12000 rpm
250 - 350 cc		11000 rpm
350 - 450 cc		10000 rpm
Over 450 cc		9000 rpm
<b>Quads</b>		
TBC		TBC rpm

Trail		
Over 600 cc		TBC rpm
Flat Track		
<b>250 - 500 cc</b>	<b>2T</b>	<b>9000 rpm</b>
<b>250 - 450 cc</b>	<b>4T</b>	<b>10800 rpm</b>

Rain and wet conditions significantly alter the laws under which sound propagates. For the risk of misleading results and unrepeatable conditions, sound testing should not be performed when it is raining or conditions are wet. The decision of the Sound Control Officer and/or FIM technical Director to continue, suspend or stop the sound controls in rainy/wet conditions is final.

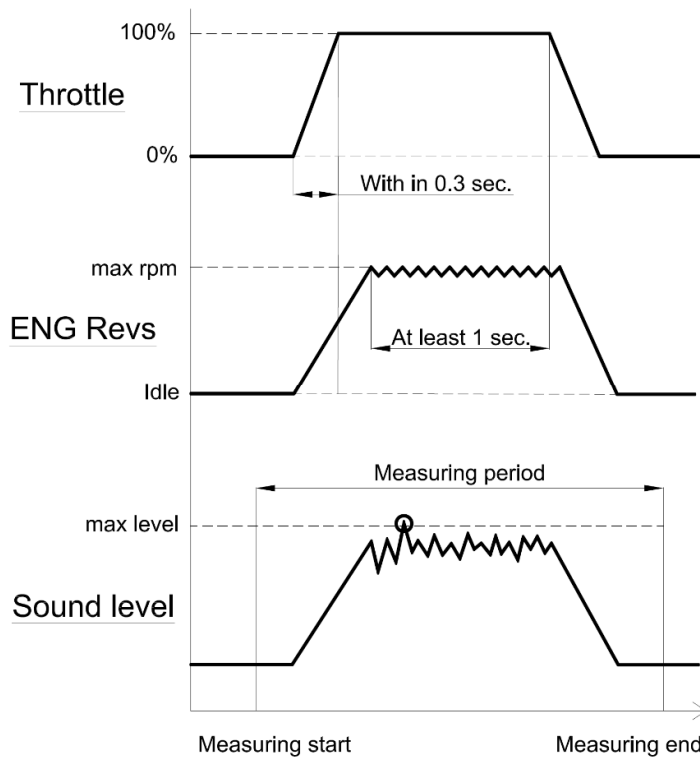

1. The Inspector shall open the throttle until full open throttle within 0.3 seconds.
2. And keep at the max rpm (at rpm limiter) at least 1 second. Then, release the throttle quickly.
3. The sound level is measured in the all period and the maximum level shall be recorded in any case. (automatically by the sound meter).

## E. SOUND LIMITS

Below are listed the maximal sound limits by category and by type of engine.

- The values that have to be respected after the race take into account the degradation of the silencer (i.e. the limit is raised of 1 dB/A).
- The values already take into account the accuracy of the method.
- No deductions for ambient temperature, pressure or altitude are allowed.
- The measured noise value shall not be rounded down to the nearest whole number.

## 1. TRIAL World Championships, Cups and Prizes

Type of engine	Maximum Sound limit in [dB/A]	
	Before the race	During or after the race
2-stroke	103.0	104.0
4-stroke	105.0	106.0

Table 1 : Sound limit for Trial

## 2. TRACK RACING World Championships, Cups and Prizes

Type of engine	Maximum Sound limit in [dB/A]	
	Before the race	During or after the race
All	115.0	116.0
2-stroke 4-stroke	(Target 113.0 + 2.0 for the precision of the method)	(Target 115.0 + 1.0 for the degradation of the silencer)
SGP4 4-stroke	111.0 (Target 109.0 + 2.0 for the precision of the method)	112.0 (Target 111.0 + 1.0 for the degradation of the silencer)

Table 2: Sound limit for Track Racing

## 3. FLAT TRACK World Championships, Cups and Prizes

Type of engine	Maximum Sound limit in [dB/A]	
	Before the race	During or after the race
<b>All</b> <b>2-stroke</b> <b>4-stroke</b>	<b>114.0</b>	<b>115.0</b>
<b>As of</b> <b>01/01/2026</b>	<b>111.0</b>	<b>112.0</b>

Table 3 : Sound limit for Flat Track

## 4. ENDURO, SUPERENDURO, HARDENDURO World Championships, Cups and Prizes

Type of engine	Maximum Sound limit in [dB/A]	
	Before the race	During or after the race
All	111.0	112.0
2-stroke 4-stroke	(Target 109.0 + 2.0 for the precision of the method)	(Target 111.0 + 1.0 for the degradation of the silencer)

Table 4: Sound limit for Enduro, SuperEnduro, HardEnduro

## 5. SAND RACES World Championships, Cups and Prizes

Type of engine	Maximum Sound limit in [dB/A]	
	Before the race	During or after the race
All	114.0	115.0
2-stroke 4-stroke	(Target 112.0 + 2.0 for the precision of the method)	(Target 114.0 + 1.0 for the degradation of the silencer)
As of 2025 2-stroke 4-stroke	111.0 (Target 109.0 + 2.0 for the precision of the method)	112.0 (Target 111.0 + 1.0 for the degradation of the silencer)

Quad: 2-stroke 4-stroke	<del>111.0</del> <b>114.0</b> (Target 112.0 + 2.0 for the precision of the method)	<del>112.0</del> <b>115.0</b> (Target 114.0 + 1.0 for the degradation of the silencer)
-------------------------------	---	---

Table 5: Sound limit for Sand Races

**As of 01/01/2027:**

Discipline/Class	Maximum Sound limit in [dB/A]	
	Before the race	During or after the race
<b>Quad: 2-stroke 4-stroke</b>	<b>111.0</b> <b>(Target 109.0 + 2.0 for the precision of the method)</b>	<b>112.0</b> <b>(Target 111.0 + 1.0 for the degradation of the silencer)</b>

Table 6: Sound limit for Sand Races Quads as from 01/01/2027

**6. CROSS-COUNTRY RALLIES & BAJAS World Championships and Cups**

Type of engine	Maximum Sound limit in [dB/A]	
	Before the race	During or after the race
All 2-stroke 4-stroke	117.0 (Target 115.0 + 2.0 for the precision of the method)	118.0 (Target 117.0 + 1.0 for the degradation of the silencer)
As of TBA 2-stroke 4-stroke	TBA (Target 10X.0 + 2.0 for the precision of the method)	TBA (Target 10X.0 + 1.0 for the degradation of the silencer)

Table 7: Sound limit for Cross-Country Rallies & Bajas

**7. MOTOCROSS World Championships, Cups and Prizes**

Discipline/Class	Maximum Sound limit in [dB/A]	
	Before the race	During or after the race
MXGP, MX2, Women MX 2-stroke 4-stroke	111.0 (Target 109.0 + 2.0 for the precision of the method)	112.0 (Target 111.0 + 1.0 for the degradation of the silencer)
Supercross (SX) 2-stroke 4-stroke	111.0 (Target 109.0 + 2.0 for the precision of the method)	112.0 (Target 111.0 + 1.0 for the degradation of the silencer)
Sidecars: 2-stroke 4-stroke	111.0 (Target 109.0 + 2.0 for the precision of the method)	112.0 (Target 111.0 + 1.0 for the degradation of the silencer)
Junior MX: 2-stroke (65/85) 2-stroke (125) 4-stroke	111.0 (Target 109.0 + 2.0 for the precision of the method)	112.0 (Target 111.0 + 1.0 for the degradation of the silencer)
Supermoto 2-stroke 4-stroke	111.0 (Target 109.0 + 2.0 for the precision of the method)	112.0 (Target 111.0 + 1.0 for the degradation of the silencer)
Snowcross 2-stroke 4-stroke	111.0 (Target 109.0 + 2.0 for the precision of the method)	112.0 (Target 111.0 + 1.0 for the degradation of the silencer)

Quad: 2-stroke 4-stroke	<del>111.0</del> <b>114.0</b> (Target 112.0 + 2.0 for the precision of the method)	<del>112.0</del> <b>115.0</b> (Target 114.0 + 1.0 for the degradation of the silencer)
-------------------------------	--	--

Table 8: Sound limit for Motocross

**As of 01/01/2027:**

Discipline/Class	Maximum Sound limit in [dB/A]	
	Before the race	During or after the race
<b>Quad: 2-stroke 4-stroke</b>	<b>111.0</b> (Target 109.0 + 2.0 for the precision of the method)	<b>112.0</b> (Target 111.0 + 1.0 for the degradation of the silencer)

Table 9: Sound limit for Quadcross as from 01/01/2027

- The values that have to be respected after the race take into account the degradation of the silencer (i.e. the limit is raised of 1 dB/A).
- The values already take into account the accuracy of the method.
- No deductions for ambient temperature, pressure or altitude are allowed.
- The measured noise value shall not be rounded down to the nearest whole number.



**FEDERATION INTERNATIONALE  
DE MOTOCYCLISME**

**FIM-MOTO.COM**

ROUTE DE SUISSE 11 | 1295 MIES | SWITZERLAND

[cti@fim.ch](mailto:cti@fim.ch)

6579006



*FEDERATION INTERNATIONALE  
DE MOTOCYCLISME*

**FIM FUELS  
REGULATIONS**

**2025**

# FIM Fuels Regulations

## *Règlement FIM pour les essences*

Modifications log		
Version	Applicable as from	Modified articles
0	01.01.2025	

Articles amended for the season 2025 are in bold type  
Articles amended since 01.01.2025 are in red and bold type





## Table of Contents

A.	INTRODUCTION .....	3
B.	REGULAR FUEL .....	4
C.	RACE FUELS .....	5
D.	TESTING LABORATORY .....	6
E.	FIM FUEL SPECIFICATION - CATEGORY 1 .....	7
F.	FIM FUEL SPECIFICATION - CATEGORY 2 .....	9
G.	FIM FUEL SPECIFICATION - CATEGORY 3 .....	11
H.	FIM FUEL SPECIFICATION - CATEGORY 4 .....	12
I.	FIM SPECIFICATIONS FOR MIXTURES OF UNLEADED FUEL(S) AND LUBRICANT .....	13
J.	OXIDANT - AIR .....	14
K.	FUELS CONTROLS .....	15
L.	FUEL SAMPLE DECLARATION FORM .....	20
M.	LIST OF FIM CERTIFIED FUELS .....	22

## A. INTRODUCTION

### **PLEASE ALWAYS REFER TO THE LATEST FIM REGULATIONS CODE IN FORCE FOR THE DISCIPLINE / COMPETITION (INCLUDING THE SUPPLEMENTARY REGULATIONS)**

All machine(s) must be fuelled with a fuel specification compliant with one of the following FIM Fuel specifications:

- Regular Fuels
- Race Fuels - Category 1
- Race Fuels - Category 2
- Race Fuels - Category 3
- Race Fuels - Category 4

For your reference and complete information, please refer to the last update of the reference documents hereunder:

- FIM FUELS REGULATIONS:

[https://www.fim-moto.com/fr/documents?tx\\_solr%5Bq%5D=fuels+regulations](https://www.fim-moto.com/fr/documents?tx_solr%5Bq%5D=fuels+regulations)

- FIM CERTIFIED FUELS LIST:

[https://www.fim-moto.com/fr/documents?tx\\_solr%5Bq%5D=certified+fuels](https://www.fim-moto.com/fr/documents?tx_solr%5Bq%5D=certified+fuels)

Every team has to declare the fuel specification they will use for the entire official event before the technical verifications (on the FIM Technical Control form). If the team use a race fuel, the team must provide the fuel certificate from the FIM appointed testing laboratory to the FIM Technical Directors.

## **B. REGULAR FUEL**

If not specified in the Technical Rules of the Championships, Cup or Prize or in the Supplementary regulation of the event, regular fuel coming from Public Fuel station can be used.

By regular fuel. It is to be understand fuel available at the fuel station with a fuel gun and with an Octane not more than 98. Local official fuel specification will be taken into account depending on the conformity of a pump station fuel.

## C. RACE FUELS

Fuel companies which supply “race” fuels (fuels other than those obtained at public pump stations) to participating teams/riders must test their fuel at against all the FIM specifications set out in Art. **E, F, G, H** of this regulation.

### **Certified fuels**

If the specifications of the fuel are in conformity to Art. **E, F, G, H** of this regulation, a certificate containing a test report and batch number will be issued to the fuel company.

The fuel company shall be able to provide a copy of such certificate to their client rider/teams before they take part in a race.

If a team and/or rider uses a Race fuel in their vehicle, it is their full responsibility and obligation to inform the FIM Technical Director (or FMN Chief Technical Steward) during the technical verifications and to present the fuel certificate provided from the FIM appointed Laboratory of that racing fuel.

Please refer to the latest list of the FIM certified fuels on the following link:

[https://www.fim-moto.com/en/documents?tx\\_solr%5Bq%5D=certified+fuels](https://www.fim-moto.com/en/documents?tx_solr%5Bq%5D=certified+fuels)

### **Appointed supplier(s) to event(s)**

In the cases in which only fuel from the appointed supplier is permitted (for a specific event or the entire World Championship, Prize or Cup), the aforementioned fuel shall have been previously tested in a FIM appointed laboratory in order to test its conformity with the FIM specifications as set out in Art. **E, F, G, H** of this regulation:

- in case of conformity, a certificate of conformity (including test report and tested batch number) shall be available and Art. **C, K** of this regulation applies in case of controls for the riders/teams;
- in case the conformity is not achieved, the FMN of the organising country/the Organiser/the Promoter shall ask the FIM for a waiver in order to enable the use of fuel not corresponding to FIM specifications. If the waiver is granted, the riders/teams will be responsible for using the fuel provided without changing its composition. Controls may be carried out by FIM.

## D. TESTING LABORATORY

For question regarding the “race” fuels and/or the testing of the fuels please contact the aforementioned testing laboratory:

**Intertek (Schweiz) AG**

Analytical Testing - Fuel, Lubricants & Combustible

Wagistraße 2

8952 Schlieren

Switzerland

Telephone: +41 43 433 78 10

Fax: +41 43 433 78 19

Email contact: [fimfuels@intertek.com](mailto:fimfuels@intertek.com).

## E. FIM SPECIFICATIONS FOR UNLEADED PETROL, CATEGORY 1

The following fuels specifications are valid for these FIM Competitions (please always refer to the latest regulations code in force for the discipline):

### FIM Circuit Racing Competitions:

- MotoGP™
- Moto2™
- Moto3™
- WorldSBK
- WorldSSP NG
- MiniGP
- Redbull Rookies Cup
- Endurance World Championship and Cup
- Women's World Championship

The following properties shall be within the following thresholds (for each property, the relative test methods to be used for the measurement are indicated):

For MotoGP/Moto2/Moto3: this fuel must be a minimum of 40% of non-fossil origin, increasing to 100% of non-fossil origin from 2027.

<b>Property</b>	<b>Units</b>	<b>Test method</b>	<b>Min.</b>	<b>Max.</b>
<b>Non-fossil components</b>	% (14C/C)	ASTM D6866-22 - Method B - AMS	40.0*	
<b>RON</b>		ISO 5164	95.0	102.0
<b>MON</b>		ISO 5163	85.0	90.0
<b>Oxygen</b>	% (m/m)	ISO 22854		3.7
<b>Benzene</b>	% (v/v)	ISO 22854		1.0
<b>Vapour pressure (DVPE)</b>	kPa	EN 13016-1		90.0
<b>Density at 15°C</b>	kg/m <sup>3</sup>	ASTM D 4052/ EN 12185	720.0	775.0
<b>Oxidation stability</b>	minutes	ASTM D 525/ EN ISO 7536	360	
<b>Existent gum</b>	mg/100ml	EN ISO 6246		5.0
<b>S</b>	mg/kg	ASTM D 5453/ EN ISO 20846		10.0
<b>N</b>	% (m/m)	ASTM D 4629		0.2
<b>Cu corrosion</b>	Rating	ISO 2160		Class1
<b>Distillation at 70°C</b>	% (v/v)	ISO 3405	22.0	50.0
<b>Distillation at 100°C</b>	% (v/v)	ISO 3405	46.0	72.0
<b>Distillation at 150°C</b>	% (v/v)	ISO 3405	75.0	
<b>Final boiling point</b>	°C	ISO 3405		210.0
<b>Residue</b>	% (v/v)	ISO 3405		2.0
<b>Olefins</b>	% (v/v)	ISO 22854		18.0
<b>Bi/Polycyclic olefins</b>	% (m/m)	GCMS		0.01
<b>Total di-olefins</b>	% (m/m)	GCMS/HPLC		1.0
<b>Aromatics</b>	% (v/v)	ISO 22854		35.0
<b>Total HC's containing only H and C and present &lt;5% each</b>	% (m/m)	Gas chromatography	30.0	
<b>Substances capable of exothermic reaction in absence of external O</b>		GCMS		Not permitted**
<b>Oxygenates other than below list</b>	% (m/m)	EN ISO 22854		0.1

<b>Methanol</b>	% (v/v)	ISO 22854	3.0
<b>Mn content</b>	mg/l	ICPOES or ASTM D3831	1.0
<b>Pb content</b>	mg/l	ICPOES or ASTM D3237	5.0
<b>Fe content</b>	mg/l	EN 16136 :2015 or ASTM D5059 – 20	5.0
<b>Ni content</b>	mg/l	EN 16136 :2015 or ASTM D5059 – 20	5.0
<b>Appearance</b>		Visual inspection	Clear and bright

All reported min. and max. thresholds (except for the non-fossil components determination) do not include the tolerance, which needs to be calculated in accordance with ISO 4259 and taken into account to correct the min. and max. thresholds.

#### List of permitted oxygenates:

Methanol, Ethanol, Iso-propyl alcohol, Iso-butyl alcohol, Methyl tertiary butyl ether, Ethyl tertiary butyl ether, Tertiary amyl methyl ether, Di-isopropyl ether, n-Propyl alcohol, Tertiary butyl alcohol, n-Butyl alcohol, Secondary butyl alcohol.

\*As it is guaranteed that all the samples will be analysed by the same laboratory, an absolute measure uncertainty of +/- 0.5% will be taken in account, as per ASTM D6866- 22 - Method B - AMS.

\*\*A limit of detection of 0.01% m/m will be applied.

#### Fuel definitions:

- Paraffins Straight chain and branched alkanes.
- Olefins Straight chain and branched monoolefins and diolefins.
- Monocyclic monoolefins (with five or more carbon atoms in the ring) with or without paraffinic side chains.
- Diolefins Straight chain or branched or monocyclic hydrocarbons (with five or more carbon atoms in any ring) with or without paraffinic side chains, containing two double bonds per molecule.
- Naphthenes Monocyclic alkanes (with five or more carbon atoms in the ring) with or without paraffinic side chains.
- Aromatics Monocyclic and bicyclic aromatic rings with or without paraffinic side chains.
- Oxygenates Organic compounds containing oxygen.
- Additive An additive is a component added to the fuel at low concentration to improve a particular property of the fuel. These include (but are not limited to) antioxidants, antiknock agents, antistatic additives and deposit control additives.
- Metals are defined as alkali metals, alkaline earth metals, transition metals, actinides, lanthanides, post-transition metals and metalloids.

## F. FIM SPECIFICATIONS FOR UNLEADED PETROL OR MIXTURES OF UNLEADED FUELS, CATEGORY 2

The following fuels specifications are valid all FIM Competitions not included in Category 1, Category 3 and Category 4.

The following properties shall be within the following thresholds (for each property, the relative test methods to be used for the measurement are indicated):

Property	Units	Min. <sup>1</sup>	Max.	Test Methods <sup>2</sup>	
Density at 15°C	[kg/m <sup>3</sup> ]	720.0	785.0	EN ISO 12185	ASTM D4052
RON	-	95.0	102.0	EN ISO 5164	ASTM D2699
MON	-	85.0	90.0	EN ISO 5163	ASTM D2700
Oxidation stability	[min]	360		EN ISO 7536	ASTM D525
Vapour pressure (DVPE)	[kPa]		100.0	EN 13016-1	ASTM D5191
Aromatics	% (V/V)		35.0	EN ISO 22854	ASTM D6839
Benzene	% (V/V)		1.0	EN ISO 22854	ASTM D6839 or D5580
Diolefins total	% (m/m)		1.0	GC-MS	HPLC
Lead	[mg/L]		5.0	ICP-OES or-EN 237	AAS
Manganese	[mg/L]		2.0	ICP-OES	AAS
Nitrogen	% (m/m)		0.2	ASTM D 4629	ASTM 5762
Olefins	% (V/V)		18.0	EN ISO 22854	ASTM D6839
Bi/Polycyclic olefins	% (m/m)		0.01	GC-MS	
Oxygen (includes 10% ethanol allowance)	% (m/m)		3.7	EN ISO 22854	EN 13132 or elemental analysis
Sulphur	[mg/kg]		10.0	EN ISO 20846	ASTM D5453
Distillation:				EN ISO 3405	ASTM D86
E at 70°C	% (V/V)	20.0	52.0		
E at 100°C	% (V/V)	46.0	72.0		
E at 150°C	% (V/V)	75.0			
Final Boiling Point	[°C]		210		
Residue	% (V/V)		2.0		
Methanol	% (V/V)		3.0		
Ethanol	% (V/V)		10.0		The only oxygenates permitted are paraffinic mono-alcohols and paraffinic mono-ethers (of 5 or more carbon atoms per molecule) with a final boiling point below 210°C.
Isopropanol	% (V/V)		12.0		
Isobutanol	% (V/V)		15.0		
tert-Butanol	% (V/V)		15.0		
Ethers (C5 or higher)	% (V/V)		22.0		
Others	% (V/V)		15.0		

Table 1 : Specifications and test methods (does not include the visual inspection)

In addition to these specifications, the appearance of the fuel, controlled by visual inspection must be clear, bright and free from solid matter and undissolved water.

The total of individual hydrocarbon components present at concentrations of less than 5% (m/m) must constitute at least 30% (m/m) of the fuel. The test method will be GC-FID (gas chromatography-flame ionisation detector) and/or GC-MS (gas chromatography-mass spectrometry).

The total concentration of naphthenes, olefins and aromatics classified by carbon number must not exceed the values given in the following table:

<sup>1</sup> All reported min. and max. thresholds do not include the tolerance, which needs to be calculated in accordance with ISO 4259 and taken into account to correct the min. and max. thresholds

<sup>2</sup> In case of dispute the test method listed in **bold** will be the reference



<b>% (m/m)</b>	<b>C4</b>	<b>C5</b>	<b>C6</b>	<b>C7</b>	<b>C8</b>	<b>C9+</b>
Naphthenes	0.1	5.0	10.0	10.0	10.0	10.0
Olefins	5.0	20.0	20.0	15.0	10.0	10.0
Aromatics			1.2	35.0	35.0	30.0

Table 2 : Naphtenes, Olefins and aromatics contents

Bicyclic and polycyclic olefins are not permitted (0.01%(m/m) max). The fuel must contain no substances which are capable of exothermic reaction in absence of external oxygen.



## **G. FIM SPECIFICATIONS FOR FULLY ADVANCED SUSTAINABLE FUEL, CATEGORY 3**

In construction through the FIM Eco-Fuels Technical Working Group 2.  
To be announced at a later stage when finalised.



## **H.FIM SPECIFICATIONS FOR PARTIALLY ADVANCED SUSTAINABLE FUEL, CATEGORY 4**

In construction through the FIM Eco-Fuels Technical Working Group 2.  
To be announced at a later stage when finalised.

## I. FIM SPECIFICATIONS FOR MIXTURES OF UNLEADED FUEL(S) AND LUBRICANT

The lubricant must not:

1. change the composition of the fuel fraction when added to the fuel
2. contain any nitro-compounds, peroxides or any other engine power boosting additives
3. contribute to an improvement in overall performance in any way
4. show a reduction in mass by evaporation of more than 10% (m/m) during the distillation up to 250°C (test method: simulated distillation GC)
5. contain more than 10% of anti-knock agents (lead, manganese, iron) (test method: ICP-OES).

Moreover, the following specifications are set for the mixture of unleaded fuel(s) and lubricant:

The following properties shall be within the following thresholds (for each property, the relative test methods to be used for the measurement are indicated):

Property	Units	Min.	Max.	Test Methods	
Density at 15°C <sup>3</sup>	[kg/m <sup>3</sup> ]	690	815	EN ISO 12185	ASTM D4052
RON	-		102	EN ISO 5164	ASTM D2699
MON	-		90	EN ISO 5163	ASTM D2700

<sup>3</sup> For the density measurement, the min. and max. thresholds do include the tolerance



**J. OXIDANT - AIR**

Only ambient air may be mixed with the fuel as an oxidant.

## K.FUELS CONTROLS

**Please always refer to the latest regulations code in force for the discipline.**

The FIM may require fuel controls, i.e. controls of the unleaded fuel, mixture of unleaded fuels or mixture of unleaded fuel and lubricant, used by riders/teams at events. These controls involve an initial sampling at the event and further testing.

### 1. Sampling and testing

Samples will be taken at the event either during Parc Fermé procedures, or during the session in the pitlane. The samples will be tested either:

- a) (Only in the case of a single fuel supplier) tested at the event using the GC test method.
- b) Delivered by a FIM courier to the FIM appointed laboratory for post event tests.

### 2. Sampling

#### Procedure A:

FIM fuel sampling for Gas Chromatography (GC) testing method at the event (when available, if not, procedure B applies).

1. The FIM Technical Director (or the FMNR Chief Technical Steward when there is no FIM Technical Director appointed) is the sole official responsible for the sampling management and supervision.
2. Riders/teams selected for fuel controls are directed to proceed with their vehicles to the area that has been designated for this purpose.
3. The FIM Technical Director/FMNR Chief Technical Steward collects the fuel from the motorcycle by using only new sample containers and pipettes/hand pumps.
4. The fuel is transferred through the use of the pipette/hand pump directly from the fuel tank into the vial A (designed for direct use in the GC machine).

During the total duration of this procedure, the motorcycle must remain in the appointed test area.

#### Procedure B:

FIM fuel sampling for the test in a FIM appointed laboratory (if Procedure A is not applicable).

1. The FIM Technical Director (or the FMNR Chief Technical Steward when there is no FIM Technical Director appointed) is the sole official responsible for the sampling management and supervision.
2. Riders/teams selected for fuel controls are directed to proceed with their vehicles to the area that has been designated for this purpose.
3. The FIM Technical Director/FMNR Chief Technical Steward collects the fuel from the motorcycle by using only new sample containers and pipettes/hand pumps.
4. The fuel is transferred through the use of the pipette/hand pump directly from the fuel tank into three containers, denominated A, B and C. The containers are closed and sealed by the FIM Technical Director/ FMNR Chief Technical Steward.

5. The FIM Technical Director/FMNR Chief Technical Steward fills in (in all its parts) and signs the Fuel Sample Declaration Form (see forms). The rider or a team representative also signs this Form, after verifying that all the information is correct.
6. The FIM Technical Director/FMNR Chief Technical Steward prepares an appropriate shipping box containing the collected A, B and C samples and a copy of the respective, signed, Fuel Sample Declaration Form. The box is then shipped to the FIM appointed laboratory by courier.

### 3. Testing

#### Procedure A:

FIM fuel testing via Gas Chromatography (GC) testing method on, during, or at the event (when available, if not, Procedure B applies).

1. One or more properties to be checked (following the relevant testing method as per Art. D, E, F, G or H) are set by the FIM for each selected rider/team.
2. The vial A must be put directly in the GC machine for GC test/analysis.
3. The threshold of result to pass the GC test is fixed at 97% of match (compared with the same batch of fuel, provided by the contracted single fuel supplier for the related discipline/championship/Cup).
4. Under 97% of match, the GC test result is failed (meaning the fuel tested is not in conformity with the fuel, provided by the contracted single fuel supplier for the related discipline/championship/Cup).
5. The full Procedure A can be made a second time upon request of the team manager (of the team which fuel is tested). The team manager can attend the full procedure.
6. There will be no protest available, only the option to immediately make a second test.
7. This result will be reported by the FIM Technical Director to the FIM nominated authorities/Officials for the related discipline/championship/Cup (e.g. FIM Stewards Panel, FIM International Jury) which will take appropriate actions.

### Procedure B:

FIM fuel testing via FIM appointed laboratory (if Procedure A not available).

1. One or more properties to be checked (following the relevant testing method as per Art. D, E, F, G or H) are set by the FIM for each selected rider/team.
2. Sample A is the first sample to be tested by the FIM appointed laboratory.
3. Sample B can be used for a second analysis if required by the FIM. The test result of the A or B sample more favourable to the rider/team is taken into account. Costs for the shipping and testing of sample A and B are paid by FIM.
4. As soon as possible after completing the testing, the FIM appointed laboratory reports the test results directly to the responsible CTI Coordinator.
5. For negative cases (i.e. conformity of the tested property(ies) with the specification), the riders/teams concerned will be individually informed by the FIM in due course, copying the rider/team's FMN, the FIM Technical Director/FMNR Chief Technical Steward, the competent authority (e.g. FIM Stewards Panel, FIM International Jury), the CTI Director, the Director and Coordinator(s) of the Sporting Commission concerned.
6. Only for positive cases following testing of sample A or B or A and B (i.e. non-conformity of one or more properties\*), the responsible CTI Coordinator notifies by electronic mail\* the rider/team concerned (including the testing results) and, 24 hours after, forwards the relevant information to the rider/team's FMN, the FIM Technical Director/ FMNR Chief Technical Steward, the competent authority (e.g. FIM Stewards Panel, FIM International Jury), the CTI Director, the Director and Coordinator(s) of the sporting Commission concerned.

\* Note: The non-conformity of one property (except the appearance) is sufficient for declaring non-conformity of the fuel or the mixture.

7. If the rider/team wishes to request a counter-expertise, he must notify the responsible CTI Coordinator by electronic mail\* accordingly, within 72 hours of receipt by the FIM of the delivery status notification pertaining to the notification of the test results to the rider/team.

- If a counter-expertise is requested, the sample dedicated to the counter-expertise is sample C and the test shall aim at checking the same property(ies) previously checked on sample A/B. The rider/team can request that sample C be tested at one of the available FIM appointed laboratories. Costs for shipping and testing of sample C are paid by the rider/team concerned.

Upon notification of the sample C results, the responsible CTI Coordinator notifies by electronic mail\* the rider/team concerned (including the testing results) and forwards the relevant information to the rider/team's FMN, the FIM Technical Director/ FMNR Chief Technical Steward, the competent authority (e.g. FIM Stewards Panel, FIM International Jury), the CTI Director, the Director and Coordinator(s) of the Sporting Commission concerned.

- If no counter-expertise is requested within the time limit, the responsible CTI Coordinator forwards the relevant information by electronic mail\* the rider/team's FMN, the FIM Technical Director/ FMNR Chief Technical Steward), the competent authority (e.g. FIM Stewards Panel, FIM International Jury), the CTI Director, Director and Coordinator(s) of the Sporting Commission concerned.

8. The competent authority of the event concerned (e.g. FIM Stewards Panel, FIM International Jury) makes a decision based on the information received. The Coordinator of the Sporting Commission concerned notifies the rider/team concerned regarding the decision by electronic mail\*.

The non-conformity of :

- A sample (in the cases B sample was not used) or
- B sample (in the cases A sample result was not conclusive) or
- A and B samples or
- A and B and C samples (in the cases B sample was used and a counter- expertise was requested) or



- A and C samples (in the cases B sample was not used and a counter- expertise was requested) automatically results in the disqualification of the rider/team from the entire event.
  - No disqualification will be applied in case of conformity of sample C.
  - Furthermore, in any case, other penalties may be applied.
- 9.** The rider/team has the right to appeal against the decision of competent authority of the event concerned (e.g. FIM Stewards Panel, FIM International Jury) in accordance with FIM Disciplinary and Arbitration Code applicable to the relevant discipline.

\* The receipt of a delivery status notification will be deemed as proof of delivery.

## L. FUEL SAMPLE DECLARATION FORM

		<h2 style="margin: 0;">FIM Fuel Sample Declaration Form</h2>														
Discipline																
IMN (xxx/xx)																
Rider/team's name																
Rider/team's number																
Rider/team's email or telephone number																
Team																
Vehicle's make																
Fuel's make and type																
Fuel origin (public station or race supplier)																
Fuel samples taken on date (dd/mm/yy)																
Fuel samples taken at (right before or after):																
<b>MOTOCROSS</b>	<b>TRIAL</b>	<b>TRACK RACING</b>	<b>ENDURO /ISDE</b>	<b>RALLIES /BAJAS</b>												
Practice <input type="checkbox"/>	Day 1 <input type="checkbox"/>	Heat n°__ <input style="width: 40px;" type="text"/>	Day 1 <input type="checkbox"/>	Day 1 <input type="checkbox"/>												
Qualifying race <input type="checkbox"/>	Day 2 <input type="checkbox"/>		Day 2 <input type="checkbox"/>	Day 2 <input type="checkbox"/>												
Race 1 <input type="checkbox"/>			Day n°__ <input type="checkbox"/>	Day n°__ <input type="checkbox"/>												
Race 2 <input type="checkbox"/>																
<table border="1" style="margin: auto; border-collapse: collapse;"> <thead> <tr> <th style="width: 15%;"></th> <th style="width: 15%;"></th> <th style="width: 70%;">Container seal n°</th> </tr> </thead> <tbody> <tr> <td style="text-align: center;"><b>Sample A</b></td> <td></td> <td></td> </tr> <tr> <td style="text-align: center;"><b>Sample B</b></td> <td></td> <td></td> </tr> <tr> <td style="text-align: center;"><b>Sample C</b></td> <td></td> <td></td> </tr> </tbody> </table>							Container seal n°	<b>Sample A</b>			<b>Sample B</b>			<b>Sample C</b>		
		Container seal n°														
<b>Sample A</b>																
<b>Sample B</b>																
<b>Sample C</b>																
<p>The above listed details refer to fuel samples taken from the fuel tank of the motorcycle specified.</p> <p><b>Sample A</b> is the first testing sample to be used by the FIM appointed laboratory</p> <p><b>Sample B</b> can be used for a second analysis if required by the FIM</p> <p><b>Sample C</b> is used if a counter-expertise is required by the rider/team.</p> <p>The serial numbers of the vial seals and the accuracy of the listed information have been verified.</p>																
Rider or team responsible name																
Rider or team responsible signature																
FIM Technical Director/ FMNR Chief Technical Steward name																
FIM Technical Director/ FMNR Chief Technical Steward signature																

		<h2 style="margin: 0;">FIM Fuel Sample Declaration Form</h2>													
Discipline															
IMN (xxx/xx)															
Rider/team's name															
Rider/team's number															
Rider/team's email or telephone number															
Team															
Vehicle's make															
Fuel's make and type															
Fuel origin (public station or race supplier)															
Fuel samples taken on date (dd/mm/yy)															
Fuel samples taken at (right before or after):															
<b>CIRCUIT RACING DISCIPLINES</b>															
Free practice	<input type="checkbox"/>														
Qualifying race	<input type="checkbox"/>														
Warm up	<input type="checkbox"/>														
Race 1	<input type="checkbox"/>														
Race 2	<input type="checkbox"/>														
<table border="1" style="margin-left: auto; margin-right: auto; border-collapse: collapse;"> <thead> <tr> <th style="width: 15%;"></th> <th style="width: 10%;"></th> <th style="width: 75%; text-align: center;">Container seal n°</th> </tr> </thead> <tbody> <tr> <td style="text-align: center;"><b>Sample A</b></td> <td></td> <td></td> </tr> <tr> <td style="text-align: center;"><b>Sample B</b></td> <td></td> <td></td> </tr> <tr> <td style="text-align: center;"><b>Sample C</b></td> <td></td> <td></td> </tr> </tbody> </table>						Container seal n°	<b>Sample A</b>			<b>Sample B</b>			<b>Sample C</b>		
		Container seal n°													
<b>Sample A</b>															
<b>Sample B</b>															
<b>Sample C</b>															
<p>The above listed details refer to fuel samples taken from the fuel tank of the motorcycle specified.</p> <p><b>Sample A</b> is the first testing sample to be used by the FIM appointed laboratory</p> <p><b>Sample B</b> can be used for a second analysis if required by the FIM</p> <p><b>Sample C</b> is used if a counter-expertise is required by the rider/team.</p> <p>The serial numbers of the vial seals and the accuracy of the listed information have been verified.</p>															
Rider or team responsible name															
Rider or team responsible signature															
FIM Technical Director/ FMNR Chief Technical Steward name															
FIM Technical Director/ FMNR Chief Technical Steward signature															

## **M. LIST OF FIM CERTIFIED FUELS**

Please refer to the latest list of the FIM certified fuels on the following link:

[https://www.fim-moto.com/en/documents?tx\\_solr%5Bq%5D=certified+fuels](https://www.fim-moto.com/en/documents?tx_solr%5Bq%5D=certified+fuels)



**FEDERATION INTERNATIONALE  
DE MOTOCYCLISME**

**FIM-MOTO.COM**

ROUTE DE SUISSE 11 | 1295 MIES | SWITZERLAND

cti@fim.ch

6579006