



**25 – 28 June 2026**

## **SUPPLEMENTARY REGULATIONS**

# INDEX

Art. 1.	Introduction .....	3
Art. 1.1	Preamble .....	3
Art. 1.2	Length of Selective Sections .....	3
Art. 1.3	Overall numbers and total distance of the itinerary .....	3
Art. 1.4	Route terrain on Selective Sections .....	3
Art. 2.	Organisation .....	4
Art. 2.1	Championships and titles for which the Baja counts .....	4
Art. 2.2	Approvals .....	4
Art. 2.3	Organiser's name, address, and contact details .....	4
Art. 2.4	Organising Committee .....	5
Art. 2.5	Stewards of the Meeting .....	5
Art. 2.6	FIA Delegates & Observer .....	5
Art. 2.7	Senior Officials .....	5
Art. 2.8	Location of Rally HQ and contact details .....	6
Art. 2.9	Digital Official Notice Board .....	6
Art. 3.	Programme in chronological order and locations .....	6
Art. 4.	Entries .....	7
Art. 4.1	Closing date for entries .....	8
Art. 4.2	Entry procedure .....	8
Art. 4.3	Number of competitors accepted and vehicle classes .....	9
Art. 4.4	Entry fees/entry fee packages .....	10
Art. 4.5	Payment .....	11
Art. 4.6	Entry fee refunds .....	11
Art. 5.	Insurance Cover .....	11
Art. 6.	Advertising and Identification .....	12
Art. 6.1	Obligatory organiser's advertising .....	12
Art. 6.2	Optional organiser's advertising .....	12
Art. 6.3	Driver's and Navigator's Identification .....	13
Art. 7.	Tyres .....	13
Art. 7.1	Regulations regarding tyres which may be used during the event .....	13
Art. 7.2	Identification of the tyres .....	13
Art. 8.	Fuel / Refuelling .....	13
Art. 8.1	Technical Requirements .....	13
Art. 8.2	Closing date for ordering space for refuelling .....	13
Art. 9.	Administrative checks .....	13
Art. 9.1	Documents to be presented: .....	13
Art. 9.2	Timetable .....	14
Art. 10.	Scrutineering, Sealing and Marking .....	14
Art. 10.1	Scrutineering, venue, and time .....	14
Art. 10.1.1	Scrutineering, mandatory documents .....	14

Art. 10.1.2 Timetable for scrutineering.....	14
Art. 10.2 Drivers' safety equipment.....	15
Art. 10.3 Installation of the Safety Tracking System and Navigation System.....	15
Art. 10.3.1 Safety Tracking System (FIA CCRSR Art. 12.1).....	15
Art. 10.3.2 Navigation System (NAV-GPS; FIA CCRSR Art. 12.2) .....	15
Art. 10.3.3 Connection of the Systems (FIA CCRSR Art. 12.3).....	15
Art. 10.3.4 GPS Data Logger .....	15
Art. 10.4 On-Board Cameras .....	15
Art. 11. Other procedures and regulations .....	16
Art. 11.1 Drivers' Briefing(s).....	16
Art. 11.2 Start Area .....	16
Art. 11.3 Ceremonial start procedures and order .....	16
Art. 11.4 Electronic start procedure at Selective Sections.....	16
Art. 11.5 Prologue .....	16
Art. 11.6 Finish procedures.....	16
Art. 11.7 Permitted early check-in.....	17
Art. 11.8 Official time used during the event.....	17
Art. 11.9 Road books delivery.....	17
Art. 11.10 Servicing of vehicles .....	17
Art. 11.11 Shakedown.....	18
Art. 11.12 Special procedures and activities.....	18
Art. 12. Identification of officials.....	19
Art. 13. Prizes .....	19
Art. 14. Final checks / Protests / Appeals / Fines.....	19
Art. 14.1 Final Checks.....	19
Art. 14.2 Protest deposit.....	19
Art. 14.3 Appeal deposit.....	19
Art. 14.4 Fines .....	19

<b>Appendix 1</b>	<b>Itinerary</b>
<b>Appendix 2</b>	<b>Names and photographs of the Competitors Relation Officer(s) and their schedules</b>
<b>Appendix 3</b>	<b>Decals and positioning of supplementary advertising.</b>
<b>Appendix 4</b>	<b>Extract from FIA Appendix L relating to overalls, helmets and any other safety requirements.</b>
<b>Appendix 5</b>	<b>Instruction for the use of the Tracking System</b>
<b>Appendix 6</b>	<b>Instructions for the use of the car-to-car communication system</b>
<b>Appendix 7</b>	<b>List of Commercial Filling Station</b>
<b>Appendix 8</b>	<b>Layout of general map</b>

## Art. 1. Introduction

Name of the event: ITALIAN BAJA 2026

Date of the event: 25 – 28 June 2026

### Art. 1.1 Preamble

This event will be run in compliance with the FIA International Sporting Code (ISC) including appendices, the FIA Cross-Country Rally Sporting Regulations (FIA CCRSR) including appendices, the WADA/NADA Codes, and the FIA Anti-Doping Regulations, as amended from time to time. The National Road Traffic Regulations of the countries the event passes shall apply. Unless provided otherwise by these Supplementary Regulations, the provisions of the above Rules and Regulations shall apply.

Any modifications, amendments and/or additions to the Rules and Regulations shall be made in the form of numbered and dated bulletins. Bulletins will be issued by the Organiser, up to the commencement of administrative checks with the approval of the FIA, after the administrative checks by the Stewards of the Meeting. Exceptionally, modifications to the itinerary may be made by the Organiser. Additional information will be published in the Rally Guide. All FIA regulations can be found at <https://www.fia.com/regulations>.

The various documents will be written in English *and Italian*. In case of any discrepancy the English text will be binding.

The FIA Cross-Country Rally Sporting Regulations are available at:

<https://www.fia.com/regulation/category/100>

### Art. 1.2 Length of Selective Sections

Prologue	14,05	km
Stage 1:	319,78	km
Stage 2:	98,37	km
<b>TOTAL</b>	<b>432,20</b>	<b>km</b>

### Art. 1.3 Overall numbers and total distance of the itinerary

Number of Stages	2	
Number of Sections (incl.Prologue)	4	
Number of Selective Sections (incl.Prologue)	4	
Total distance of the itinerary	674,88	km

### Art. 1.4 Route terrain on Selective Sections.

Gravel/dirt tracks	97	%
Open desert	[Number]	%
Dunes	[Number]	%
[other surfaces]	3	%

Prologue	Safety Type Track
Stage 1	Safety Type Track
Stage 2	Safety Type Track

## **Art. 2. Organisation**

### **Art. 2.1 Championships and titles for which the Baja counts**

#### **FIA World Cup for Cross-Country Bajas**

- World Baja Cup for Drivers
- World Baja Cup for Navigators
- World Baja Cup for Teams
- World Baja Cup for Junior Drivers
- World Baja Cup for Master Drivers
- World Baja Cup for Ultimate Drivers
- World Baja Cup for Ultimate Navigators
- World Baja Cup for Challenger Drivers
- World Baja Cup for Challenger Navigators
- World Baja Cup for SSV Drivers
- World Baja Cup for SSV Navigators
- World Baja Cup for Stock Drivers
- World Baja Cup for Stock Navigators

#### **FIA European Cup for Cross-Country Bajas**

- European Baja Cup for Drivers
- European Baja Cup for Navigators
- European Baja Cup for Teams
- European Baja Cup for Junior Drivers
- European Baja Cup for Master Drivers
- European Baja Cup for Ultimate Drivers
- European Baja Cup for Ultimate Navigators
- European Baja Cup for Challenger Drivers
- European Baja Cup for Challenger Navigators
- European Baja Cup for SSV Drivers
- European Baja Cup for SSV Navigators
- European Baja Cup for Stock Drivers
- European Baja Cup for Stock Navigators

Italian Cross-Country Championship and Trophies associated  
Hungarian Cross-Country Championship associated

### **Art. 2.2 Approvals**

ASN registration number / Visa

Visa No.: 06/26 Approved on: 09/04/2026

FIA VISA

Visa No.: 04WBC/260427 Issued on: 27/04/2026

### **Art. 2.3 Organiser's name, address, and contact details**

Organiser: ASD Fuoristrada Club 4x4 Pordenone  
Organiser's representative: Luciano Pellarin  
Mauro Tavella  
Street/P.O. Box: Via Mantica Princivalle, 34  
Post code/city: 33170 – Pordenone  
Phone and fax: +39 0434 208484  
E-mail: info@italianbaja.com

#### Art. 2.4 Organising Committee

Organising Committee: Luciano Pellarin  
Mauro Tavella  
Moreno Olivetto  
Harry Blanks  
Italo Giopp

#### Art. 2.5 Stewards of the Meeting

	Name
Stewards of the Meeting (Chairperson):	Jordi PARRO (ESP)
2 <sup>nd</sup> FIA Steward	Joe CORCORAN (IRL)
ASN Steward	Tiziano TONIAL (ITA)
Secretary of the Stewards	Sonia MARTINEZ

#### Art. 2.6 FIA Delegates & Observer

	Name
FIA Observer	Antonio MEDEIROS (PRT)
FIA Technical Delegate	Katerina JANOVSKA (FIA)
FIA Technical Delegate Assistant.	Ludovic PATURET (FIA)
FIA Safety Delegate	Yann DION (FIA)

#### Art. 2.7 Senior Officials

	Name	License no.
Event Director:	Mauro TAVELLA	
Clerk of the Course:	Mauro FURLANETTO	37939
Deputy Clerk of the Course:	Flavio CANDONI	22754
Deputy Clerk of the Course:	Sara DE CASTRO	243153
Ass. to the Clerk of the Course	Ziad JAMOUS	TBA
Secretary of the Event:	Mara TEMPORIN	508558
Chief Safety Officer:	Mauro TAVELLA	508560
Deputy Chief Safety Officer:	Moreno OLIVETTO	456195
Scrutineers (Chief Scrutineer):	Daniele FEMIANO	34088
Scrutineers (Chief Scrutineer):	Luigi SALVADOR	337435
Scrutineer	Bruno DE GRANDI	337434
Scrutineer	Thierry MORUZZI	501194
Scrutineer	Nello DORETTO	31680
Scrutineer	Stefano DRIUSSI	511275
Scrutineer	Silvio FARINA	305501
Scrutineer	Violana PASSON	215832
Scrutineer	Massimo LAZZARO	215845
Chief Medical Officer (CMO):	Andrea LANA	453750
Timekeeping (Chief Timekeeper):	Federico BALDI	457080
Competitors' Relations Officer (CRO):	Giuliano AIROLDI	
Competitors' Relations Officer (CRO):	Paola VALMASSOI	
Results	TBA	
Press Officer:	Carlo RAGOGNA	
Environmental Officer:	Lorenzo DA RE	

## Art. 2.8 Location of Rally HQ and contact details

Name: Pordenone Fiere SpA  
Street: Viale Treviso, 1  
Post code, city: 33170 – Pordenone  
Phone: +39 393 355 7267  
E-mail: Info@italianbaja.com

### Rally HQ in operation:

Wednesday, 24 June	from	8:00 am	to	9:30 pm
Thursday, 25 June	from	7:30 am	to	11:00 pm
Friday, 26 June	from	8:00 am	to	10:00 pm
Saturday, 27 June	from	6:30 am	to	9:00 pm
Sunday, 28 June	from	7:00 am	to	3:00 pm

### Service parc in operation:

Wednesday, 24 June	from	8:00 am	to	9:30 pm
Thursday, 25 June	from	7:00 am	to	11:00 pm
Friday, 26 June	from	6:30 am	to	10:00 pm
Saturday, 27 June	from	5:30 am	to	10:00 pm
Sunday, 28 June	from	6:30 am	to	6:00 pm

The Times refers to the opening and closing times of the entrance gates to the “Fiera” for the Service parc (see art.3)

## Art. 2.9 Digital Official Notice Board

There will be no physical Official Notice Board at the Rally HQ

The Official Notice Board is the SPORTITY Application on mobile phones and tablets

Password: **ITBAJA2026**

## Art. 3. Programme in chronological order and locations

Date:	Time:		Location:
March 30	6:00 pm	Issuing of Rally Guide	<a href="http://www.italianbaja.com">www.italianbaja.com</a> / Sportity
April 27	9:00 am	Publishing of the supplementary regulations	<a href="http://www.italianbaja.com">www.italianbaja.com</a> / Sportity
April 27	9:00 am	Entries open	
May 22	6:00 pm	Closure date of entries at reduced fees	
June 10	6:00 pm	Closure date of entries	
	6:00 pm	Closing date for shakedown registration	
	6:00 pm	Closing date for order of extra service in SP	
	6:00 pm	Closing date for order space for refuelling	
June 16	6:00 pm	Publication date of entry list	Official Notice Board
25 June	7:00 am	Gate Opening – Service Parc	Fiera – Gate SUD
	8:00 am	Opening of Media Centre and accreditation	Fiera – Ground floor
	8:00 am/ 7:00 pm	Collection of material and documents	Fiera - Hall
	8:00 am/ 7:00 pm	Administrative checks	
	8:30 am/ 7:30 pm	Collection of rally safety tracking system and NAV-GPS	
	9:00 am/ 8:00 pm	Scrutineering – sealing & marking of components	Fiera – Pav. 5 Bis
	8:00 pm	Team managers and/or Drivers' briefing	Fiera – Sala Zuliani

	08:15 pm	Publication of Amended Entry List	Official Notice Board
	8:30 pm	Publication of start list for Ceremonial Start	Official Notice Board
	9:00 pm	Opening Pre-Start Area	Fiera - Behind pav.5
	9:30 pm	Ceremonial Start	Pordenone – Piazza XX Settembre
	11:00 pm	Gate Closure – Service Parc	Fiera – Gate SUD
26 June	6:30 am	Gate Opening – Service Parc	Fiera – Gate SUD
	7:00 am/ 8:00 am	Re-scrutineering for car which did not pass	Fiera – Pav. 5 Bis
	9:00 am/ 12:30 pm	Shakedown	San Martino al Tagliamento
	2:30 pm	Press conference before the rally	Media Centre – Ground Floor
	4:00 pm	Publication of start list for Prologue	Official Notice Board
	4:25 pm	Issuing of the road book, maps	Service OUT
	4:45 pm	Start of the Rally – Prologue (TCP0)	Service OUT
	6:10 pm	Finish of Section Prologue (estimated time of 1 <sup>st</sup> car)	Service IN
	7:00 pm	Publication of the Prologue provisional classification	Official Notice Board
	8:00 pm	Selection of Starting Position after QS	Fiera – Pav.5
	9:00 pm	Publication of start list for Stage 1	Official Notice Board
11:00 pm	Gate Closure – Service Parc	Fiera – Gate SUD	
27 June	5:30 am	Gate Opening – Service Parc	Fiera – Gate SUD
	6:00 am/ 6:30 am	Re-scrutineering, cars to re-start after retirement	Fiera – Pav. 5 Bis
	7:25 am	Issuing of the road book, maps for Stage 1	Service OUT
	7:45 am	Start of Stage 1, Section 1 (estimated time of 1 <sup>st</sup> car)	Service OUT
	1:55 pm	Start of Stage 1, Section 2 (estimated time of 1 <sup>st</sup> car)	Service OUT
	5:45 pm	Finish of Stage 1 (estimated time of 1 <sup>st</sup> car)	Service IN
	7:00 pm	Publication of start list for Stage 2	Official Notice Board
10:00 pm	Gate Closure – Service Parc	Fiera – Gate SUD	
28 June	6:30 am	Gate Opening – Service Parc	Fiera – Gate SUD
	6:30 am/ 7:00 am	Re-scrutineering, cars to re-start after retirement	Fiera – Pav. 5 Bis
	7:10 am	Issuing of the road book, maps for Stage 2	Service OUT
	7:30 am	Start Stage 2, Section 3 (estimated time of 1 <sup>st</sup> car)	Service OUT
	11:40 am	Finish of Stage 2 (estimated time of 1 <sup>st</sup> car)	Parc Fermè
	12:30 pm	Publication of Provisional Classifications (overall and by groups)	Official Notice Board
	14:00 pm	Podiums Ceremony / Prize-giving	Fiera – Pav. 5
	to follow	Post-rally Press Conference	Fiera – Pav. 5
		Final scrutineering; Immediate after arrival in the finish (following the marshals' instructions)	Fiera – Pav. 5 Bis
	Publication of Final Classifications After the Stewards have declared the Classification final.	Official Notice Board	

#### Art. 4. Entries

The organization reserves the right to refuse the registration to any participant, particularly in consideration of the following criteria:

- The respectability and/or morals of the Competitor likely for example to jeopardise the safety rules, the application of which are essential to the smooth running of the Event.
- The integrity and/or the reputation of the Event and/or of the Organizer;
- Logistical constraints obliging the Organizer to limit the number of Competitors or to limit should the case may be, their Assistance;

- The non-payment on the required dates of the Registration fees and/or the existence of precedents of non-payment of any sums dues to the Organizer within the 5 (five) years preceding the registration application to the Event.

The organization declines all responsibility in the event of theft or damage to equipment within the various structures of the organization.

#### **Art. 4.1 Closing date for entries**

See programme in chronological order (SR Art. 3) and FIA CCRSR Art. 17

#### **Art. 4.2 Entry procedure**

**Art. 4.2.1** Entries must be submitted in accordance with the FIA CCRSR Art. 16 – Art. 18.

See also FIA International Sporting Code Art. 3.8 – Art. 3.14

An electronic entry application (Internet) will be accepted on the organisers' website <https://www.italianbaja.it/en/for-pilots/registration/fia-european-cup>

**The entry form must be accompanied by a copy of the valid competitor's licence.** If one of the drivers will be the competitor, he must hold a valid a competitor's licence and a driver's competition licence.

To be accepted competitors must send proof of payment of the entry fee by email to the secretariat [entry@italianbaja.com](mailto:entry@italianbaja.com) by the closing date of entries.

The following documents must be attached to the entry form:

- Copy of the valid competitor's licence
- Copies of the driver's and navigator's competition licences
- Copies of the driver's and navigator's valid driving licences
- Copies of the driver's and navigator's passports or identification
- Copy of the ASN authorisation, for all foreign competitor and / or drivers
- Copy of the Vehicle Registration papers
- Copy of the FIA Technical Passport
- Copy of the vehicle insurance cover certificate
- On-Board Team Camera form

**All competitors taking part in the baja must ensure that their drivers and navigators sign the driver declarations and undertakings form as specified in Article 4.2.2 of the present supplementary regulations.**

Mailing address for entry form:

Name: Fuoristrada Club 4x4 Pordenone c/o TOP Srl  
 Street: Via Mantica Princivalle, 34  
 Post code/city: 33170 - Pordenone  
 E-mail: [entry@italianbaja.com](mailto:entry@italianbaja.com)

An entry application (also made electronically) will be accepted only if accompanied by the total entry fees. The entry fee must be credited in full to the organiser's bank account:

<b>Banca di Credito Cooperativo Pordenone e Monsile</b>	<b>TOP srl</b>
Bank	Account holder
<b>IT 781 08356 12503 000 000 131002</b>	<b>ICRAITRR9W0</b>
IBAN	BIC

#### **Art. 4.2.2 Driver declaration and undertakings**

**FIA Cross-Country Rally Sporting Regulations, Article 1.1.7:** *"All competitors taking part in a Championship event must ensure that their drivers and navigators sign the driver's declarations and undertakings form as attached in Appendix XI."*

Please print, fill in and sign the Driver's Declarations and Undertakings available at:

<https://www.fia.com/regulation/category/100> (under RELATED DOCUMENTS)



The completed and signed Driver's Declarations and Undertakings must be handed to the organiser at the administrative checks.

#### Art. 4.2.3 FIA Baja Cups and Points

In order to score points, competitors **must register** with the FIA up to the closing date for entries for the first baja for which they wish to score points.

Registrations must be made using the entry form available on the FIA website:

<https://registrations.fia.com/bajas>

**NEW - Selection of events** (FIA World and European Baja Cups): The driver/team **must designate a maximum number of bajas** on which he wishes to score points:

- **Six (6)** for the **World Cup**
- **Six (6)** for the **European Cup**
- **Four (4)** for the **Middle East Cup**

This designation must be made before the closing date for entries for each baja, using the form on the FIA website (link above). **No changes** may be accepted **after the closing of entries** for each baja.

The FIA Baja Cups for **Teams** is reserved for **legal entities** holding a competitor's licence. Only registrations with a proof of payment of the registration fee will be accepted.

For further information, please refer to V2, Art. 3.1.9, 3.3. to 3.5 and V3, Art 3.4, 3.5 (Regional Cups) of the FIA CCRSR.

#### Art. 4.3 Number of competitors accepted and vehicle classes

**Art. 4.3.1** The number of competitors shall be limited to: 70

The minimum number of entered automobiles required is: 20.

If that number is not reached, the Organiser may cancel the competition after obtaining the FIA's approval.

#### Art. 4.3.2 Eligible cars

- **Ultimate:** Prototype Cross-Country Vehicles.
- **Stock:** Series Production Cross-Country Cars.
- **Challenger:** Lightweight Prototype Cross-Country Vehicles.
- **SSV:** Modified Production Cross-Country Side-by-Side Vehicles.

#### Art. 4.3.3 Groups/Classes of vehicles

Group	Class	Vehicle
ULTIMATE (ULT)	T1+	Prototype Cross-Country Vehicles 4x4 complying with 2026 Appendix J, Art. 285-11
	T1.1	Prototype Cross-Country Vehicles 4x4 complying with 2026 Appendix J, Art. 285
	T1.2	Prototype Cross-Country Vehicles 4x2 complying with 2026 Appendix J, Art. 285
	ULTS	SCORE Buggy vehicles approved by the FIA (see FIA CCRSR, Art. 8.4)

<b>STOCK</b> (STK)	STK	Series Production Cross-Country Cars complying with 2026 Appendix J, Art. 284
	T2.1	Series Production Cross-Country Cars complying with 2024 Appendix J, Art. 284
	T2.2	Series Production Cross-Country Vehicles with expired homologation, complying with 2024 Appendix J, Art. 284
<b>CHALLENGER</b> (CHG)	CHG1	Lightweight Prototype Cross-Country Vehicles complying with 2026 Appendix J, Art. 286 (turbo up to 1,050cc)
	CHG2	Lightweight Prototype Cross-Country Vehicles complying with 2026 Appendix J, Art. 286 (NA up to 1,050cc)
	T3. U	Lightweight Prototype Cross-Country Vehicles complying with 2026 Appendix J, Art. 286-14
	CHGS	SCORE UTV vehicles approved by the FIA (see Art. 8.4)
<b>SSV</b>	SSV1	Cross-Country Side-by-Side (SSV) Vehicles complying with 2026 Appendix J, Art. 286A (turbo up to 1050cc and atmo from 1050cc to 2000cc)
	SSV2	Cross-Country Side-by-Side (SSV) Vehicles complying with 2026 Appendix J, Art. 286A (atmo up to 1050cc)
	T4	Modified Production Cross-Country Side-by-Side (SSV) Vehicles with a FIA Technical Passport issued before 31.12.2025 and complying with 2024 Appendix J, Art. 286A

See also FIA CCRSR Art. 8 for additional provisions.

#### Art. 4.4 Entry fees/entry fee packages

With organiser's optional advertising (see also FIA CCRSR Art. 20)

GROUP	from 27 April to 22 May		from 23 May to 10 June	
	Without VAT	With VAT 22%	Without VAT	With VAT 22%
Private Entrant	3600€	4392€	4200€	5124€
Legal Entrant / Priority Driver	4200€	5124€	4600€	5612€

Without organiser's optional advertising: (see also FIA RRSR Art. 20)

For competitors refusing the Organiser's optional advertising, the amount of the Entry fees will be increased by 60%

#### Information regarding VAT

- Invoices issued to EU and foreign companies are not subject to VAT (VAT – Reversed charge)
- Invoice issued to individuals from any nationality or to Italian companies are subject to VAT – tax rate of 22%

INCLUDED IN THE ENTRY FEES – PRIVATE ENTRANT	INCLUDED IN THE ENTRY FEES – LEGAL ENTRANT
Participation in the event	Participation in the event
Organiser's Civil Responsibility insurance	Organiser's Civil Responsibility insurance
Professional medical resources (ambulance)	Professional medical resources (ambulance)
Safety equipment	Safety equipment
Recycling	Recycling
Safety Tracking and Navigation System	Safety Tracking and Navigation System
Paper Road Book (per day)	Paper Road Book (per day)
Baja car stickers (set)	Baja car stickers (set)
"Service" stickers"	"Service" "Truck" & "Team Manager" stickers"
ID bracelets	ID bracelets for crew and Team Manager
70 sqm 1st car and 50 sqm for the other cars	100 sqm for each car;
50 sqm for each SSV	70 sqm for each SSV
Prize giving Ceremony	Prize giving Ceremony

<b>FEES NOT INCLUDE</b>
The purchase of mounts and accessories for the safety device
Electricity

**Competitors are required to pay (during check-in at Administrative Checks) a deposit of 250€ which will be refunded at the end of the event upon return of safety device and cleaning service area.**

#### **Art.4.4.1 Additional fees:**

<b>ADDITIONAL</b>	<b>Without VAT</b>	<b>With VAT 22%</b>
Shakedown	300€	366€
Additional Service Area	150€ per 10 sqm	183€ per 10 sqm
Additional Truck plates	300€	366€
Additional Service plates	150€	183€

#### **Art.4.4.2 Access to the Rally**

Access to the rally is restricted exclusively to people wearing an identification wristband (competitors, support staff, organisers, press, VIPs) and to vehicles officially registered. Checking by the organization of this identification will be systematic at each service point and zone.

Presentation of the identity wristband is compulsory each time it is requested by the organizer or their representatives. In the case where the wristband becomes damaged, the person must get the wristband replaced by the competitor's service, in exchange for damaged item.

#### **Art. 4.5 Payment**

Any entry not accompanied by the entry fee shall be, according to Art. 3.9.3 of FIA International Sporting Code, null and void. The entry fee shall be paid by bank transfer to the account indicated below (in the latter case, adequate proof of payment must be attached to the entry form):

Organiser's bank details:

**Banca di Credito Cooperativo Pordenone e Monsile**  
Bank

**IT 781 08356 12503 000 000 131002**  
IBAN

**TOP srl**  
Account holder

**ICRAITRR9W0**  
BIC

#### **Art. 4.6 Entry fee refunds**

The entry fee shall be refunded in full:

- if the event does not take place
- to teams whose entry application is rejected.

The organiser may partially refund entry fees if a competitor cannot take part in the event due to a duly proved case of force majeure.

Subject to the application reaching the organiser per email.

The deduction will be:

- 50 % of the entry fees for requests received until 30 days before the administrative checks;
- 25 % of the entry fees for requests received until 8 days before the administrative checks;

Other situations of force majeure not mentioned are subject to analysis and approval of the Organising Committee.

#### **Art. 5. Insurance Cover**

The entry fee includes the insurance premium to insure civil liability of competitors against all third part risks whilst taking part in the Italian Baja.

The provided indemnity under this special insurance is € 25.000.000,00 covering each incident or accident.

- The Organisers decline liability for any accident caused to competitors and competing cars during the whole of the event, any in case of cataclysm, riots, demonstrations, vandalism etc. Competitors and crewmembers will have to suffer all consequences (damages, fines and penalties) created by any accidents. Organisers also decline any liability for breach of the Italian Laws and regulations. Injury to the drivers themselves or damage to participating cars are not covered by this insurance.

- Entrants and drivers are free to take on at their own convenience any individual insurance policy that they deem fit, independently from the above-mentioned liability insurance.
- Vehicles carrying service, auxiliary, and/or any other equivalent special plates issued by the Organiser are not covered by the event's insurance policy. These vehicles circulate under the sole responsibility of their owners and the organizer bears no responsibility for them.
- The Organiser guarantees the recover of the injured driver in the Udine or Pordenone hospital. All medical costs and hospitalization, after repatriation to Europe, remain entirely at the expense of the beneficiary.  
Competitors are recommended to take information about the cover afforded by their racing driver's licence and take out additional insurance with an insurance company of their choice.

The insurance policy shall be drawn up with this Insurance Company:

Name of the Company: **Civitus – Allianz Spa**  
Address: **viale Bruno Buozzi 11/13, 00197 ROMA**  
Policy n.: **505756530**

## **Art. 6. Advertising and Identification**

See Appendix 3 of these SR "Decals and positioning of supplementary advertising".

The organiser will provide each crew with the advertising and identification panels, which must be affixed to their vehicles in the stated positions prior to scrutineering. No modifications to the panels are allowed. However, they may be cut out if the shape of the bodywork does not allow the panels to be affixed in one piece.

### **Art. 6.1 Obligatory organiser's advertising**

#### **Rally plate:**

*Communicated via Bulletin*

Size of rally plates (width x height):

- General: 43x21cm
- Groups Challenger/SSV front plate: 19x18cm

*Communicated via Bulletin*

These plates must be affixed, parallel to the wheel axle, to the front and rear of the Vehicle. These plates shall incorporate the Competitor's race number and may include advertising.

#### **Size of race number panels (width x height):**

- Groups Ultimate/Stock: 36x36cm
- Groups Challenger/SSV: 30x30cm

*Communicated via Bulletin*

These panels must be affixed to the right and left sides of the vehicle, on the front door, in the area between the wheel arches provided they are fully visible from the side, and on the roof of the Vehicle, readable in the direction of travel.

#### **Windscreen Band:**

This banner, which may incorporate the Competitor's race number, must be affixed to the upper part of the windscreen. No other advertising sticker may be affixed under it.

Size of windscreen band (width x height): 110x10cm

### **Art. 6.2 Optional organiser's advertising**

Additional organiser's advertising:

*Communicated via Bulletin*

Spaces on the vehicle that must be kept free:

*Size of optional advertising panels (width x height):*

- Groups Ultimate/Stock: 36x36cm
- Groups Challenger/SSV: 30x30cm

*For Groups Challenger/SSV, a metal bracket fixed to the rear rollbars can be added to allow the correct affixing of these panels.*

*Communicated via Bulletin*

### **Art. 6.3 Driver's and Navigator's Identification**

See Art.21 of the FIA CCRSR.

## **Art. 7. Tyres**

### **Art. 7.1 Regulations regarding tyres which may be used during the event**

See Art. 10 of the FIA CCRSR and Art. 10 of Variation V2 of the FIA CCRSR  
The maximum number of tyres to be used by FIA T1+ Priority drivers is **10**

### **Art. 7.2 Identification of the tyres**

In accordance with Art. 10.6 of the FIA CCRSR, FIA Priority drivers entered with Class T1+ vehicles must use tyres fitted with FIA barcodes.

If a tyre is also equipped with a specific permanent RFID Tag approved by the FIA (see FIA Technical List No. 54) and integrated in the tyre during the production process, before moulding and before the vulcanisation of the tyre itself, the data of the RFID Tag may also be used to identify this tyre.

## **Art. 8. Fuel / Refuelling**

All type of fuel must follow Appendix J Art. 266. (Art. 56 of the FIA CCRSR).

The use of a Diesel fuel in compliance with Appendix J Art. 266-B.2.3 (Paraffinic Diesel, including HVO) or Art. 266-B.3.3 (AS Diesel) is mandatory for all T1+ class vehicles fitted with a Diesel engine.

### **Commercial Filling Station**

According to Article 54.1 of FIA CCRSR the list of commercial filling station is as follows:

- Published in the Appendix 7
- Published in the Road book

Competitors entered with Challenger or SSV vehicles must obtain their fuel from the commercial filling stations (see CCRSR Art. 56.1.3)

### **Refuelling Zone**

See Art. 54 and 55 of the FIA CCRSR and Art. 266 of the Appendix J

The team is responsible for the refuelling.

A Refuelling Zone (RZ) will be installed adjacent to the Service Out (see Appendix 8 "Layout of General Map HQ") which can be used by the teams, using their own fuel and complying with the safety rules required by the articles above mentioned. The Road Book, Maps and Itinerary indicate the public filling stations where it is allowed to fill.

The Refuelling Zone (RZ) will be at:

Pordenone Fiere: "Parking SUD" (N 45°56.775' - E 12°39.142')

**It is mandatory to reserve the area for refueling.**

### **Art. 8.1 Technical Requirements**

See Art. 56.2 of the FIA CCRSR (Refuel Couplings)

### **Art. 8.2 Closing date for ordering space for refuelling**

10 June at 6:00 pm

## **Art. 9. Administrative checks**

### **Art. 9.1 Documents to be presented:**

(see Art. 22 of the FIA CCRSR)

To keep the time required for the administrative checks to the necessary minimum, make sure to bring and present the following documents:

- Competitors' licence
- Driver's and navigator's competition licences (if one of the drivers should be the competitor, he must also hold a competitors' licence)
- Driver's and navigator's ID cards/passports
- Driver's and navigator's valid driving licences valid for the vehicle entered.
- Driver's and navigator's signed *Driver's declaration and undertakings* forms
- ASN authorisation for all foreign competitors and/or drivers and navigators
- Completion of all details on the entry form
- Vehicle registration certificate
- Authorisation of the owner of the vehicle (if different from the competitor)
- On-Board Team Camera form (if any)

## Art. 9.2 Timetable

See programme (SR Art. 3)

Individual times to be published in a Bulletin.

- A time control (V1) will be installed immediately before administrative checks
- Any delay at the presentation at this time control will result in the following fines:

From 1 to 15 minutes	100€
From 16 to 30 minutes	200€
> 30 minutes	500€
> 60 minutes	Report to the Stewards

**If, due to proven logistical difficulties, a team anticipates that it will be unable to attend the administrative checks by a certain time, it must notify [entry@italianbaja.com](mailto:entry@italianbaja.com) by email before the closing date for entries (10 June).**

## Art. 10. Scrutineering, Sealing and Marking

See Article 23 and Article 24 of the FIA CCRSR.

### Art. 10.1 Scrutineering, venue, and time

Cars may be presented at scrutineering by a representative of the team. See programme (SR Art. 3)

#### Art. 10.1.1 Scrutineering, mandatory documents

- Cars' complete original FIA Homologation Document (if applicable)
- FIA Technical Passport
- SOS / OK board (DIN A3 format)

The installation of the tracking system and the NAV-GPS will be checked at scrutineering.

The complete original FIA homologation form / FIA Technical Passport and all other necessary certifications/documents must be available for final checks.

#### Art. 10.1.2 Timetable for scrutineering

See programme (SR Art. 3)

A detailed schedule will be issued by means of a Bulletin

- A time control (V2) will be installed immediately before the scrutineering area
- Any delay at the presentation at this time control will result in the following fines:

From 1 to 15 minutes	100€
From 16 to 30 minutes	200€
> 30 minutes	500€
> 60 minutes	Report to the Stewards

## **Art. 10.2 Drivers' safety equipment**

All items of clothing including helmets and FHR (Front Head Restraint) intended to be used, e.g. HANS devices, must be presented for scrutineering. They shall be checked for compliance with Appendix L, Chapter III.

Each vehicle must be equipped with a medical kit from the FIA Technical List n°83, that must be placed inside the cockpit, and a survival kit according to FIA CCRSR Appendix IV-2.1 and the defined Safety Type (see SR Art. 1.4).

## **Art. 10.3 Installation of the Safety Tracking System and Navigation System**

### **Art. 10.3.1 Safety Tracking System (FIA CCRSR Art. 12.1)**

All vehicles must **only** be fitted with the Safety Tracking System(s) provided by the Organiser. The instruction for the use of the Tracking System is in the Appendix 5 of these Supplementary Regulations.

The system to be used on the Italian Baja is the BE TRACED. All competitors must have this system, provided by the Organisation, in order to pass the Scrutineering.

The system will be collected (see SR art.3 – Programme) either by the crew or a representative and must be installed before the vehicle is brought to scrutineering.

The Competitor must contact FIXUP directly to order and rent support/power supply kits for this equipment **(The components kit is not included in the entry fee)**.

For further information and orders, please contact:

FIXUP:

Tel. +39 030 205 3201

Email: motorsport@betraced.it

### **Art. 10.3.2 Navigation System (NAV-GPS; FIA CCRSR Art. 12.2)**

Competitors are obliged to be equipped with one or two Navigation System(s) (NAV-GPS) downloaded with the waypoints given by the Organiser. When a crew uses two NAV-GPS, the primary one will be identified by the supplier with a distinctive label.

Crews on ITALIAN BAJA 2026 will be equipped by the organization with BE TRACED system that integrates the «car-to-car communication system» into the GPS. NAV/GPS devices shall be collected and installed before the Scrutineering. FIXUP will collect the devices from the vehicles at the finish Parc Fermé or service park for retired competitors. The information relevant to the installation of the system on the vehicle is available on the rally website and from BE TRACED.

The Competitor must contact FIXUP directly to order and rent support/power supply kits for this equipment **(The components kit is not included in the entry fee)**.

For further information and orders, please contact:

FIXUP:

Tel. +39 030 205 3201

Email: motorsport@betraced.it

### **Art. 10.3.3 Connection of the Systems (FIA CCRSR Art. 12.3)**

The specifications for the standard power connector are laid down in the FIA CCRSR Appendix VI.

It is the competitor's responsibility to ensure that the Safety Tracking System(s) and the NAV-GPS always remain permanently connected and switched on with the antenna connected throughout the duration of the competition.

### **Art. 10.3.4 GPS Data Logger**

Vehicles selected by the FIA after the publication of the entry list may be equipped with a GPS Data Logger to monitor their performances during the event.

See FIA CCRSR Article 13.1.

## **Art. 10.4 On-Board Cameras**

See FIA CCRSR Article 11.2 and 11.3

Any competitor wishing to use an on-board camera must:

- Fill out the request form available on the event website (<https://www.italianbaja.it>)
- Send the form to [entry@italianbaja.com](mailto:entry@italianbaja.com) by 10 June 2026;

Team cameras must be mounted on the car at the time of scrutineering. Mountings must comply with Article 283-2 of Appendix J. All camera locations and mountings must be shown and approved at Scrutineering prior to the start of the race. After scrutineering, on-board cameras may not be moved without the approval of the scrutineers.

Crews failing to comply with these provisions will be reported to the stewards.

### **Art. 10.5 Electronic Equipment**

Any radio or electronic means of communication, or any other device not expressly permitted in FIA CCRSR regulations is forbidden on board the vehicles.

## **Art. 11. Other procedures and regulations**

### **Art. 11.1 Drivers' Briefing(s)**

See programme (SR Art. 3)

At the first briefing of the event, the participation of at least one crew member is compulsory. Any crew not attending the pre-event briefing will incur a penalty of 100,00 €.

### **Art. 11.2 Start Area**

Before the start of the competition element of the event, all the competing vehicles will be assembled in a starting area, into which vehicles must be driven before the start time as detailed below:

- The start area will be set up behind Pavilion 5; competitors MUST enter the start area as specified in Article 3 of the programme in these regulations.
- The start area will be subject to checks. Access will be restricted to crew members, VIPs and media representatives in possession of appropriate identification/accreditation.
- Cars must be driven by one of the drivers or a team representative into the start area, where any form of assistance is strictly prohibited; any breach of this rule will be reported to the stewards.

Any entry and any delay in the pre-start area outside the time window indicated in art. 3 of these regulations will be sanctioned by the C.o.C. with a fine of 100 €.

### **Art. 11.3 Ceremonial start procedures and order**

See Programme (SR Art.3)

The procedure for going to the Ceremonial Start will be set out in a bulletin.

It will take place in Pordenone (Piazza XX Settembre), in accordance with the programme. Competitors will drive their vehicles up the ramp in the starting order designated for the ceremonial start.

### **Art. 11.4 Electronic start procedure at Selective Sections**

See Art. 42.2 FIA CCRSR

On the special stages the start will be given by an electronic system of count down. The electronic system shows the last 15 seconds countdown, followed by the GO word that will be blinking for 3 seconds. The countdown will be discounted second by second and will be clearly visible by the crew from the starting position. A photocell placed 50 cm in front of the starting line will be used to detect jump starts. Should the electronic start system fail the start will be given as specified in art. 42.3 FIA CCRSR.

### **Art. 11.5 Prologue**

See Programme (SR Art. 3)

Following the prologue, the selection of starting positions will take place at 8.00 pm in Pav.5 – “Parterre”

### **Art. 11.6 Finish procedures**

At the end of the stage 2, all cars shall pass the finish ramp (Fiera – Pav. 5) for interviews and then go to the Parc Fermé until its opening on the instructions of the Stewards.

- The podium and prize-giving will take place according to Article 3 of these regulations. The presence of both crew members is mandatory.

- The prize-giving will take place by awarding prizes to the first group and then to the first five in descending order according to the provisional overall classification.

**Art. 11.7 Permitted early check-in.**

P1A – P1B – 2A – 3A

**Art. 11.8 Official time used during the event.**

GPS time (Italian time=GMT+2) will be the official time for the entire event.

**Art. 11.9 Road books delivery**

The Organiser will issue the Road Book one day at a time.  
The Road Book will be distributed to each competitor 20 minutes prior to their SS start time.

**Art. 11.10 Servicing of vehicles**

**Art. 11.10.1 Service Areas / Bivouacs**

The Service Park will be a Bivouac as defined by article 2 and articles 50 and 51 of 2026 FIA CCRSR. Article 49 of the 2026 FIA CCR SR will be applicable during Service B (Stage 1) which are 70-minute timed services.

From TCP0 onwards, service of a competing car may be carried out in Service Areas (Service Parks and Bivouacs) and road sections as permitted under the FIA CCRSR.

The speed of vehicles in the service parks/bivouacs may not exceed 20kph

All the Teams which have to go to the own service area have to go before in the **Service Accreditation Centre (SAC)**. **GPS POINT: N 45°56.836' – E 12°39.301'**

**FOR THE TRUCKS (over 3500kg):**

Entry is **ONLY** permitted on Wednesday 24 June from 8:30 am to 12:30 pm from the south gate (N 45° 56.853' – E 12° 39.230')

**FOR THE SERVICE VEHICLES (Up to 3500kg):**

Entry is permitted on Wednesday 24 June from 2:00 pm to 9.00 pm from the south gate (N 45° 56.853' – E 12° 39.230')

**SAC will be open on Wednesday 24 June from 8:30 am to 12:30 pm and from 2:00 pm to 9:00 pm**, and there will receive the service plates and instructions to follow for the own service area.

All the Teams will be placed by the Organizer in the Service Areas.

Once positioned, only the service or passenger transport vehicles equipped with a pass (Service, Team Manager) will be able to enter and exit the service park. The rest of the vehicles will not be able to leave the Service Park until the end of the event.

One “Service” plate will be provided to each competitor for free, which can be used for any vehicle, except truck. Extra plates are available with the following fees:

ADDITIONAL	Without VAT	With VAT 22%
Additional Service Area	150€ per 10 sqm	183€ per 10 sqm
Additional Truck plates	300€	366€
Additional Service plates	150€	183€

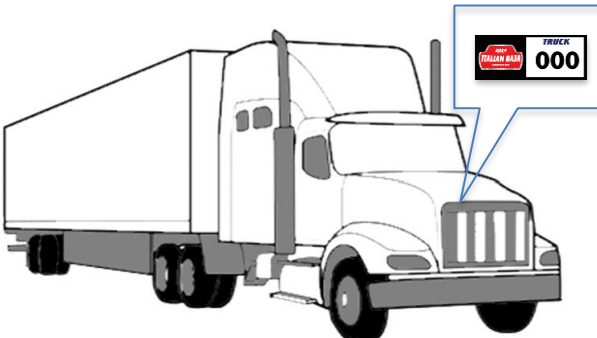

"TRUCK" Plate:

- Vehicles over 3500kg.
- These vehicles can enter the service park **ONLY** on Wednesday, 24 June from 8:30 am to 12:30 pm and must be parked there until the end of the event.

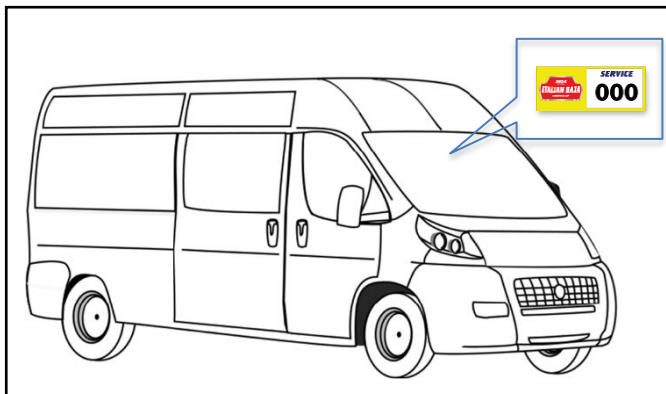

**“SERVICE” Plate:**

- Vehicles up to 3,500 kg (van) used as service assistance.
- These vehicles can enter in the service park on Wednesday, 24 June from 2:00 pm to 9:00 pm.
- During the race, these vehicles may access the service park on every day of the event.

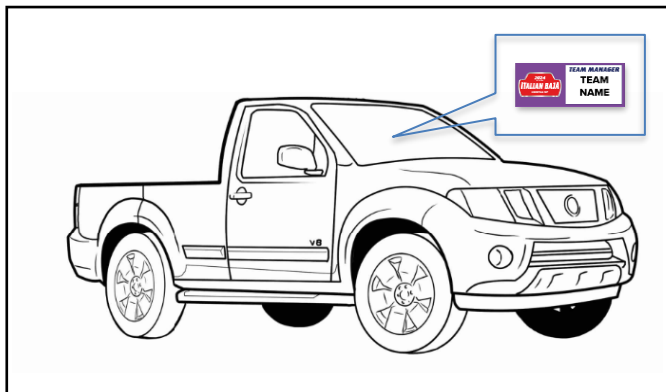

**“TEAM MANAGER” Plate:**

- Vehicles up to 3,500 kg for the transfer of the team staff.
- These vehicles can enter in the servicepark every day of the event.

**Art. 11.10.2 Service allowed in Selective Section**

In accordance with article 49 of the FIA CCR SR, any service is forbidden during Selective Sections. Only crews with FIA groups vehicles still in the competition for the current Stage/SS may assist each other.

**Art. 11.10.3 Flexi Service**

Not applicable

**Art. 11.10.4 Tyre Fitting Zone**

Not applicable

**Art. 11.11 Shakedown**

See Art.29 of the FIA CCRSR

On Friday 26 June, 9:00 am to 12:00 pm, the 6,90 km Shakedown will take place in San Martino al Tagliamento.

The entry fee for the Shakedown is 300,00€ (plus VAT, where applicable)

Participation must be indicated on the entry form, and payment must be made at the same time as the race entry fee

Before the administrative checks at check-in, you will be given a ticket to collect your roadbook.

The roadbook can be collected from the Service Out from 8:00 am on Friday 26 June by handing the ticket to the Competitor Relations Officer.

**Art. 11.12 Special procedures and activities**

**Art. 11.12.1 Availability of participants**

Participants who park their vehicles in the Parc Fermé upon passing the finish line, must remain available by phone (mobile) until the final classification have been posted.

**Art. 11.12.2 Classification**

The final classification will not be distributed after the event. The final classification will be published on the Official Notice Board SPORTITY

## Art. 12. Identification of officials

Competitors Relation Officer	<i>Red T-Shirt with CRO inscription</i>
Scrutineers	<i>Black T-Shirt with Scrutineer inscription</i>
Post Chiefs:	<i>Red Tabards</i>
Special Stage Commanders:	<i>Red Tabards</i>
“Caposettore – Safety”	<i>Red Tabards with Caposettore – Safety inscription</i>
Marshals:	<i>Orange or Yellow Tabards</i>
Timekeepers:	<i>Violet Tabards</i>
Media	<i>Green Tabards</i>

## Art. 13. Prizes

Overall classification:	<i>1<sup>st</sup>, 2<sup>nd</sup>, 3<sup>rd</sup> Trophy</i>
Classification by groups/classes	<i>1<sup>st</sup> Trophy</i>
Overall Team Classification	<i>1<sup>st</sup> Trophy</i>

## Art. 14. Final checks / Protests / Appeals / Fines

### Art. 14.1 Final Checks

Time and location: see programme (SR. Art. 3)

Any teams required to undergo final checks must immediately follow the instruction of the marshals in charge, even if this prevents them from proceeding to one or more-time controls (TC). The complete original FIA homologation form, the FIA Passport and other necessary certifications must be available for final checks.

### Art.14.2 Protest deposit

The protest deposit is: **EUR 1.000**

If a protest requires the dismantling and re-assembly of a clearly defined part of the car, any additional deposit will be specified by the Stewards upon a proposal of the Chief Scrutineer (FIA International Sporting Code Art. 13.4.3)

### Art. 14.3 Appeal deposit

The appeal deposit for an international appeal is published on the FIA website:

<https://www.fia.com/international-court-appeal>

All protests and/or appeals must be lodged in accordance with Articles 13 and 15 of the FIA International Sporting Code and, where applicable, with Chapter 4 of the FIA Judicial and Disciplinary Rules.

### Art. 14.4 Fines

In accordance with Article 12.8 FIA International Sporting Code, the payment of the fines must be done online, within 48 hours of their notification, at the following address: <https://fiafines.fia.com>.

Any delay in making payment may entail Suspension during the period a fine remains unpaid.

## Appendix 1 – Itinerary

Prologue							Friday, 26 June 2026
Sunrise 05:19							Sunset 21:04
TC	LOCATION	SS	LIAISON	TOTAL	ALLOTTED	1° CAR	
SS		km	km	km	TIME	due	
P0	Fiera Service OUT - Start Tyre Control Zone (5 min)					16:45	
RZ1	Refuelling Zone - Fiera (20 min.) Distance to next refuel		0,12 (14,05)	(26,16) (40,21)			
CF1	Commercial Filling Station - Q8 (20 min.) Distance to next refuel		3,28 (14,05)	(26,16) (40,21)			
P1	Cordenons via Pasch		9,40	11,29	00:40	17:25	
DSS P	<b>PROLOGUE - "Giulia Maroni"</b>				(00:05)	17:30	
ASS P	<i>Parereit</i> <i>Maximum Time 20'</i>	14,05	<i>expected Time of arrival</i>		(00:08)	(17:38)	
P1A*	Fiera - Technical Zone IN		16,76	30,81	00:22	(18:00)	
P1B*	Fiera - Technical Zone OUT / Service IN (after released by the scrutineers)				00:10	(18:10)	
<b>Service A</b>							
PROLOGUE TOTALS		14,05	26,16	40,21			
Rel 0.3 del 28.03		35%	65%	100%			

\* early check-in allowed

Stage 1							Saturday, 27 June 2026
Sunrise 05:20							Sunset 21:04
TC	LOCATION	SS	LIAISON	TOTAL	ALLOTTED	1° CAR	
SS		km	km	km	TIME	due	
0	Fiera - Start Stage 1 (Service A OUT) Tyre Control Zone (5 min)					07:45	
RZ2	Refuelling Zone - Fiera (20 min.) Distance to next refuel		0,12 (159,89)	(63,47) (223,36)			
CF2	Commercial Filling Station - Q8 (20 min.) Distance to next refuel		3,28 (159,89)	(66,63) (226,52)			
1	Cordenons		11,29	11,29	00:40	08:25	
DSS1A	<b>SS1 - FVG 1</b>				(00:05)	08:30	
ASS1A	<i>San Paolo</i> <i>Maximum Time 1h e 40'</i>	84,10	<i>expected Time of arrival</i>		(01:00)	(09:30)	
<b>Neutralization Zone 1</b>							
DSS1B	<b>Madrisio</b>		6,68		00:15	(09:45)	
ASS1B	<i>BASILIANO</i> <i>Maximum Time 1h e 30'</i>	75,79	<i>expected Time of arrival</i>		(01:00)	(10:45)	
1A	Fiera - Regrouping 2 IN Technical Zone		45,38	223,24	01:00	(11:45)	
1B	Fiera - Regrouping OUT - Service IN <b>Service B</b>				max. 01:00	(12:45)	
1C	Service OUT Tyre Control Zone (5 min)				01:00	(13:45)	
RZ3	Refuelling Zone - Fiera (20 min.) Distance to next refuel		0,12 (159,89)	(63,35) (223,24)			
CF3	Commercial Filling Station - Q8 (20 min.) Distance to next refuel		3,28 (159,89)	(63,35) (223,24)			
2	Cordenons		11,29		00:40	14:25	
DSS2A	<b>SS2 - FVG 2</b>				(00:05)	14:30	
ASS2A	<i>San Paolo</i> <i>Maximum Time 1h e 40'</i>	84,10	<i>expected Time of arrival</i>		(01:00)	(15:30)	
<b>Neutralization Zone 2</b>							
DSS2B	<b>Madrisio</b>		6,68		00:15	(15:45)	
ASS2B	<i>BASILIANO</i> <i>Maximum Time 1h e 30'</i>	75,79	<i>expected Time of arrival</i>		(01:00)	(16:45)	
2A *	Fiera - Leg finish Finish leg <b>Service C</b>		45,38	446,48	01:00	(17:45)	
STAGE 1 TOTALS		319,78	126,70	446,48			
PROLOGUE TOTALS		14,05	26,16	40,21			
PROLOGUE + STAGE 1 TOTALS		333,83	152,86	486,69			
Rel 0.3 del 28.03		69%	31%	100%			

\* early check-in allowed

Stage 2				Sunday, 28 June 2026		
Sunrise 05:20				Sunset 21:04		
TC	LOCATION	SS	LIAISON	TOTAL	ALLOTTED	1° CAR
SS		km	km	km	TIME	due
2B	Fiera - Start Stage 2 (Service B OUT)					07:30
	Tyre Control Zone (5 min)					
RZ4	Refuelling Zone - Fiera (20 min.)		0,12			
	Distance to next refuel	(98,37)	(89,82)	(188,19)		
CF4	Commercial Filling Station - Q8 (20 min.)		3,28			
	Distance to next refuel	(98,37)	(89,82)	(188,19)		
3	Dignano		41,90	42,02	01:25	08:55
DSS3A	SS3 - Tagliamento				(00:05)	09:00
ASS3A	<u>Bonzicco - Dignano</u>	38,39	<i>expected Time of arrival</i>		(00:25)	(09:25)
	<i>Maximum Time 45'</i>					
	Neutralization Zone 3					
DSS3B	Madrizio		6,68		00:15	(09:40)
ASS3B	<u>Vacile</u>	59,98	<i>expected Time of arrival</i>		(01:00)	(10:40)
	<i>Maximum Time 75'</i>					
3A*	Fiera - technical zone		41,24		01:00	(11:40)
	Parc Fermè					
	FIA Event Prize Giving / Podium					14:00
STAGE 2 TOTALS		98,37	89,82	188,19		
PROLOGUE + STAGE 1 TOTALS		333,83	152,86	486,69		
ALL TOTALS		432,20	242,68	674,88		
Rel 0.4 del 21.04		64%	36%	100%		

\* early check-in allowed

## Appendix 2 Names and photographs of the Competitors Relation officer(s) and their schedules

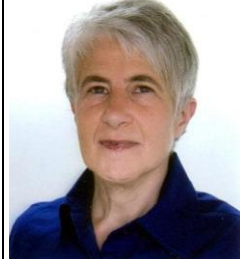
	<b>Giuliano AIROLDI</b>		<b>Paola VALMASSOI</b>
	<b><u>Mob.</u></b> <b><u>+39 335 229 734</u></b>		<b><u>Mob.</u></b> <b><u>+39 338 811 7120</u></b>
	<b><u>Lic. 465866</u></b> <b><u>ACLSPORT</u></b>		<b><u>Lic. 374137</u></b> <b><u>ACLSPORT</u></b>

<b>THURSDAY 25 JUNE</b>			
<b>TIME</b>	<b>EVENT</b>	<b>VENUE</b>	<b>NAME</b>
08:00 – 19:00	Administrative Checks	Fiera - Hall	AIROLDI
9:00 – 20:00	Scrutineering	Fiera – Pav. 5 Bis	VALMASSOI
20:00	Team Managers and/or Drivers' Briefing	Fiera – Sala Zugliani	AIROLDI/VALMASSOI
<b>FRIDAY 26 JUNE</b>			
07:00 – 08:00	Re-scrutineering for car which did not pass	Fiera – Pav. 5 Bis	VALMASSOI
08:00	Issuing of the road book for Shakedown	Fiera – Service OUT	AIROLDI
16:25	Issuing of the road book, maps for Prologue	Fiera – – Parterre Pav. 5	AIROLDI/VALMASSOI
16:45	Start of the Rally (TC0)	Fiera – Parterre Pav. 5	AIROLDI/VALMASSOI
18:10	Service A	Fiera	AIROLDI
20:00	Selection of Starting Position for Stage 1 Section 1	Fiera – Sala Zugliani	VALMASSOI
<b>SATURDAY 27 JUNE</b>			
06:00 – 06:30	Re-scrutineering for car which did not pass	Fiera – Pav. 5 Bis	VALMASSOI
07:25	Issuing of the Road Book, maps for Stage 1	Fiera – Service OUT	AIROLDI
From 11:45	Regrouping 2 IN	Fiera	AIROLDI/VALMASSOI
From 12:45	Service B	Fiera	AIROLDI/VALMASSOI
From 17:45	Service C	Fiera	AIROLDI/VALMASSOI
<b>SUNDAY 28 JUNE</b>			
06:30 – 07:00	Re-scrutineering for car which did not pass	Fiera – Pav. 5 Bis	VALMASSOI
07:10	Issuing of the Road Book, maps for Stage 2	Fiera – Service OUT	AIROLDI
11:40	Parc Fermé IN	Fiera	AIROLDI/VALMASSOI
After TC3A	Final Scrutineering	Fiera – Pav. 5 Bis	AIROLDI/VALMASSOI
14:00	Podium Ceremony / Prize Giving	Fiera – Pav. 5	AIROLDI/VALMASSOI

## Appendix 3 – Decals and positioning of supplementary advertising

---

Group IDENTIFICATION		Mandatory	Optional
<b>Ultimate / Stock:</b>			
<b>1</b>	2 number plates (36x36cm)	x	
<b>2</b>	1 roof panel (36x36cm)	x	
<b>3</b>	2 rally plate (43x21cm)	x	
<b>4</b>	1 windscreen band (110x10cm)	x	
<b>Challenger / SSV:</b>			
<b>5</b>	2 number plates (30x30cm)	x	
<b>6</b>	1 roof panel (30x30cm)	x	
<b>7</b>	2 rally plate (19x18cm)	x	
<b>8</b>	1 windscreen band (110x10cm)	x	
<b>ORGANIZER ADVERTISING</b>			
<b>9</b>	<b>Ultimate / Stock:</b> 2 panel (36x36cm)		x
<b>10</b>	<b>Challenger / SSV:</b> 2 panel (30x30cm)		x

### Placement of advertising

Identification numbers and the plate, as well as compulsory and optional advertising, must be fitted to the vehicle before scrutineering and must be visible for the duration of the rally.

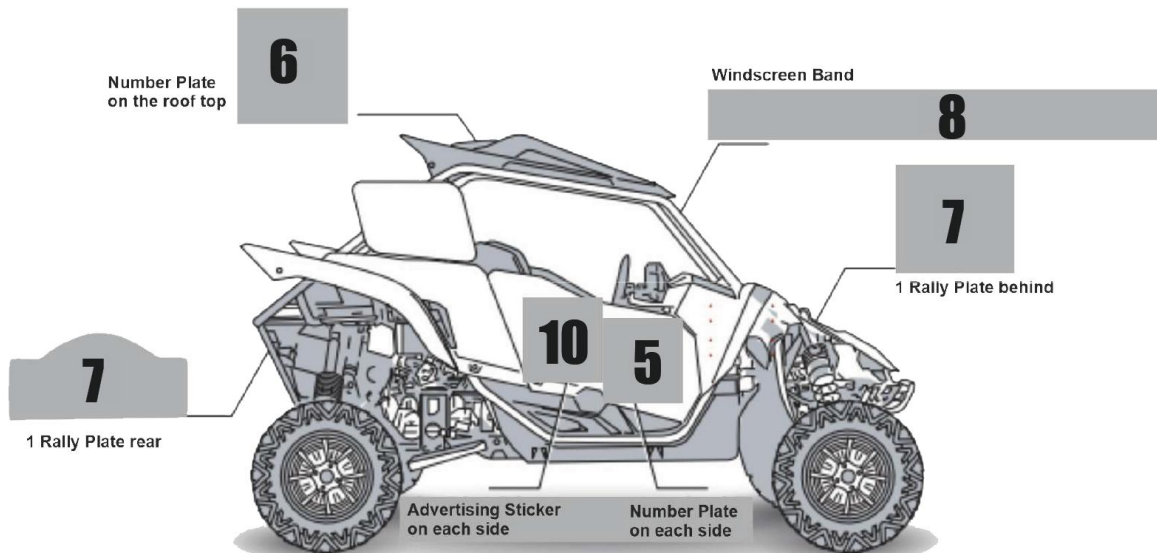
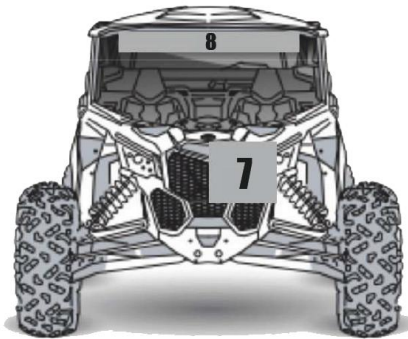
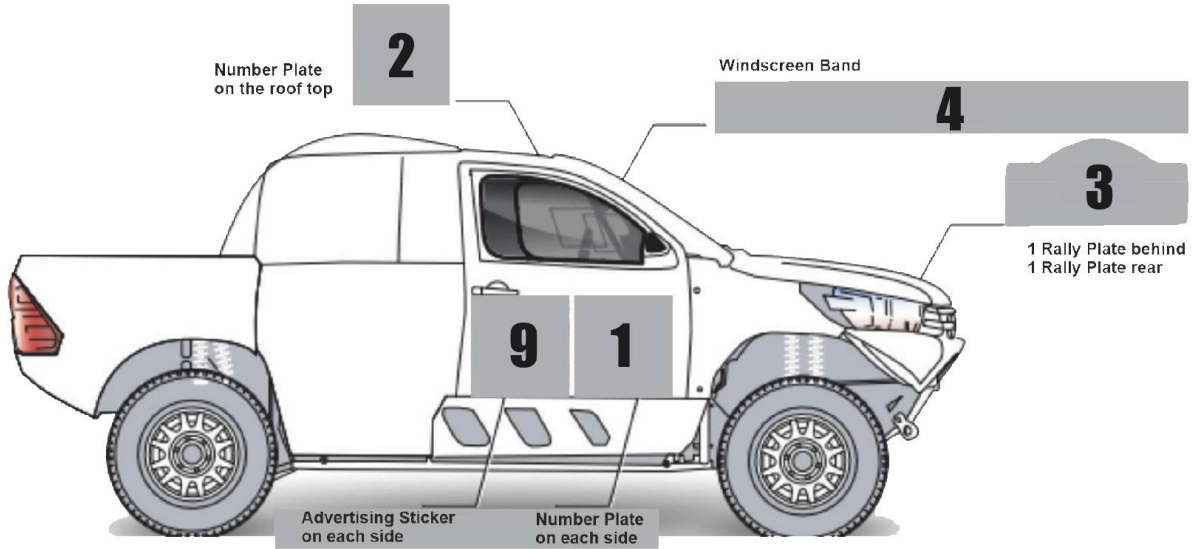

## Appendix 4 – Extracts from FIA ISC Appendix L relating to overalls, helmets and any other safety requirements.

---

All competitors are reminded of Appendix L of the FIA International Sporting Code, in particular its Chapter III - Drivers' Equipment.

### **Helmets (Appendix L, Chapter III, Art. 1)**

All crews must wear crash helmets homologated to one of the FIA standards listed in Appendix L.

Wearing an open-face helmet is prohibited on vehicles that are not designed with a windshield.

Crews of vehicles without windscreens must wear full-face helmets, of which the chin bar is an integral part of the helmet structure.

### **Frontal Head Restraint (FHR, Appendix L, Chapter III, Art. 3)**

All crews must use FIA approved FHR systems homologated to FIA standard 8858.

Approved FHRs, anchorages and tethers are listed in Technical List N° 29.

See also helmet compatibility chart in Appendix L, Chapter III, Art. 3.3.

### **Flame-resistant clothing (Appendix L, Chapter III, Art. 2)**

All drivers and navigators must wear overalls as well as gloves (optional for navigators), long underwear, a balaclava, socks and shoes homologated to the FIA 8856-2018 (Technical List N° 74). Please pay special attention to the prescriptions of Art. 2 **concerning the correct wearing of the clothing elements! See also FIA Cross-Country Rally Sporting Regulations Article 47.1.**

**Any FIA-approved 8856-2018 garment customised using printing or transfers must be accompanied by a certificate from the manufacturer.**

### **Overgarments**

If necessary due to weather conditions and after approval of the Clerk of the Course, it is allowed to use a waterproof overgarment on top of the drivers' equipment, provided it complies with EN 14116 standard. The use of garments with index 3 is strongly recommended.

### **Biometric Devices (Appendix L, Chapter III, Art. 2.1)**

Drivers may wear a device to collect biometric data during racing.

- If the biometric device is integrated into a protective garment homologated to FIA Standard 8856, the garment shall be homologated to FIA Standards 8856 and 8868-2018.
- If the biometric device is a stand-alone device, then the device must be homologated to FIA Standard 8868-2018 only. This device must be worn in addition to the garment homologated to FIA Standard 8856.

### **Wearing of jewellery (Appendix L, Chapter III, Art. 5)**

The wearing of any type of jewellery, such as but not limited to, neck chains, bracelets or watches is prohibited during the competition. Exceptions to this rule, providing the CMO and/or Medical Delegate do not consider that due to size or location they may delay rescue or hinder emergency care, are:

- i. the wearing of watch(es) by navigators, on the condition that the watch(es) is worn over the overall,
- ii. the wearing of a single band-style ring providing it does not restrict the natural range of motion of the hand, and
- iii. the wearing of body piercing(s) providing they are not worn in and/or around the oral cavity.

#### **RELATED LINKS:**

FIA International Sporting Code and appendices:

<https://www.fia.com/regulation/category/123>

FIA Technical Lists:

<https://www.fia.com/regulation/category/761>

## Appendix 5 Instruction for the use of the Tracking System

---

### TRACKING SOLUTION USER GUIDE

<https://www.betraced.com/wp-content/uploads/2026/03/Be-Traced-Tracking-solution-drivers-guide.pdf>



### TRACKING SOLUTION KIT INSTALLATION GUIDE

<https://www.betraced.com/wp-content/uploads/2025/10/Be-Traced-Tracking-solution-kit-installation-guide.pdf>



## **Appendix 6    Instructions for the use of the car-to-car communication system**

---

will be published on Sportity (organiser's documents)

## Appendix 7 List of Commercial Filling Station

---

The Commercial Filling Station will be:

Filling station	Address	GPS point	Type of fuel	Remarks
<b>Q8</b>	Viale Aquileia Pordenone	45° 57.864' N 12° 40.366' E	DIESEL Gasoline 100 octane	
<b>DELLE VEDOVE</b>	Via Musile Pordenone	45°57.018' N 12°41.736'E	DIESEL Gasoline 98 octane	Washing area
<b>TAMOIL</b>	Corso Verdi, Spilimbergo	46°5.936' N 12°51.248' E	DIESEL Gasoline 98 octane	
<b>ESSO</b>	S.S. Napoleonica Talmassons	45°56.319' N 13°7.224' E	DIESEL Gasoline 98 octane	

20 minutes time allocated for refuelling is included in the scheduled time for the road section.

## Appendix 8 General Layout

### General Map HQ

