



SUPPLEMENTARY REGULATIONS

VERSION RELEASED ON 30.09.2025



CONTENT

1. INTRODUCTION	3
2. ORGANISATION	3
3. PROGRAMME IN CHRONOLOGICAL ORDER AND LOCATION	5
4. ENTRIES	7
5. INSURANCE COVER	13
6. ADVERTISING AND IDENTIFICATION	14
7. TECHNICAL REQUIREMENTS	14
8. FUEL	14
9. ADMINISTRATIVE CHECKS	15
7. SCRUTINEERING	16
8. OTHER PROCEDURE AND REGULATIONS	18
9. OTHER PROCEDURES	20
10. PRIZES	22
11. PROTESTS	22
12. CATERING	22
13. HOTEL and TENTED BIVOUAC ACCOMMODATION	22
Appendix 1 - PRELIMINARY ITINERARY	24
Appendix 2 - SPECIFIC SAFETY AND SURVIVAL EQUIPMENT	27
Appendix 3 - VEHICLE IDENTIFICATION AND ADVERTISING	29
Appendix 4 – FERRY INFORMATION	32
Appendix 5 – OK / SOS BOARD	33
Appendix 6 - CONTROL SIGNS	34
Appendix 7 - CONTROL ZONE STANDARDS	35
Appendix 8 - ROAD BOOK ZONE SIGNAGE	38
Appendix 9 - ROAD BOOK LEXICON	39
Appendix 10 - ROAD BOOK EXAMPLES	40
Appendix 11 – TIME CARD - SAMPLE	42

1. INTRODUCTION

Name of the event: **Fenix Rally 2025**

Date of the event: **29.10 – 06.11.2025**

1.1. Preamble

RBI SPORT is the organizer of the fourth edition of Fenix Rally, named for 2025: “Fenix Rally 2025” (hereafter named “the rally”), an international event to be held from 29th October to 06th November 2025 in Tunisia. **All participants have to be in Monastir, Tunisia on 30.10.2025.**

The rally is organized in compliance with the RBI Sporting Regulations, the Technical regulations, these Supplementary Regulations and Appendices, which supersede all other regulations. The National Road Traffic Regulations of the countries the event passes shall apply. Unless provided otherwise by these Supplementary Regulations, the provisions of the above Rules and Regulations shall apply.

Any modifications, amendments and/or additions to the Rules and Regulations shall be made in the form of numbered and dated bulletins. These bulletins will be issued by the Organiser Exceptionally, modifications to the itinerary may be made by the Organiser. Additional information will be published in the Rally Guide.

All RBI Regulations can be found at <https://www.fenix-rally.com/>

Should any dispute arise as to the interpretation of these regulations, only the Panel of Stewards and the Jury have the authority to decide.

The various documents may be written in English, French and German. In case of any discrepancy the English text will be binding.

The organizer reserves the right to interpret, change and supplement these Regulations and to cancel part of the itinerary or the complete rally. The organizer does not take any liability for damages and/or losses and/or harms both occurred to Competitors/Crews and/or their personnel and/or their accompanying persons and/or their equipment and caused by them damages and/or losses and/or harms towards third parties, through the whole duration of the Rally. By signing the entry form the Competitor/Crews, his personnel and his accompanying persons declare obey to these regulations as well as to traffic rules, fire safety and other applicable regulations at the Rally route and the place of accommodation.

2. ORGANISATION

2.1. Trophies for which the Rally counts:

Cross Country category

2.2. Approvals

FTA Visa No: TBA

FTM Visa No: TBA

2.3. Organisation, address and contact details

RBI SPORT Ltd.
St. Peterburg Blvd. 75
4006 Plovdiv, Bulgaria
Tel.: +359 32 277 993
Fax: +359 32 277 990
office@rbi-sport.com

2.4. Organising Committee

Head of the Organising Committee:	Alexander KOVATCHEV – President of RBI Sport
Members:	Hichem AMEUR – President Federation Tunisienne de l’automobile (FTA) Sami TRABELSi – President Fédération Tunisienne de Motocyclisme (FTM) Mehdi BACHHAMBA Marwa DJELIDI– ONTT Ministry of Tourism and Ministry of Youth and Sport Jamel DEBABI – Vice President National Automobile Club de Tunisie Vilena KOVATCHEVA – RBI Sport Marketing manager Daniela ROUSSEKOVA – RBI Sport Administration manager

2.5. Jury (for Enduro and ATV)

Jury President:	Mr. Mahmoud ESSOUSSI, FIM License N° 16433
1 st Jury Member:	Mr Hatem Zarguni FIM Licence: 16436
2 nd Jury Member:	

2.6. Stewards of the meeting (for SSV, Cars and Trucks)

Steward of the meeting (chairperson):	Mr. Ivan MARINOV
2 nd Steward:	Mr. Ivan Stoilov
ASN Steward	TBA

2.7. Senior officials

Event Director:	Mr. Alexander KOVATCHEV
Clerk of the Course – Enduro & ATV	Mr. Chamseddine ZEMZEMI, FIM License N° 16437
Clerk of the Course	Mr. Alexander KOVATCHEV
Deputy Clerk of the Course	Mr. Marko MISSON
Secretary of the Event	Mrs. Daniela ROUSSEKOVA
Chief Safety Officer	Mr. Dimitar LAZAROV
Deputy Chief Safety Officer	Mr. Jamel DEBABI
RBI Technical Coordinator	Mr. Dimitar UZUNOV
Chief Scrutineer	Mr. Jürgen TEICHERT
Scrutineer	Mr. Thomas SCHMIDT
Chief Medical Officer (CMO)	Dr. Sebastian Kuc
Timekeeping (Chief timekeeper)	Mrs. Kalina NEDKOVA
Competitor Relations Officer (CRO)	Mr. Maksimilian MISSON
GPS Tracking Officer	Mr. Georgi DANEV
Press Officer	Mr. Paolo BARALDI
Environmental Officer	Mr. Denis KOCH

2.8. Location of Rally HQ and contact details

“Rally HQ” (Rally Office) will be at the competitors’ disposal to assist with information. It will be placed in the rally hotel or in the centre of the bivouac and will be clearly marked.

Opening and closing work hours will be noticed in the Official Rally Guide.

2.9. Official notice board (NB) / Digital Official Notice Board (DNB)

The Official Notice Board is the SPORTITY Application on mobile phones and tablets.
Password: FENIX-RALLY

“Push” notifications show any new document that is posted on the Digital Notice Board.

The Sportity App can be downloaded from Google Play or AppStore. Download from AppStore:

<https://apps.apple.com/ee/app/sportity/id1344934434>

Download from Google Play:
<https://play.google.com/store/apps/details?id=com.sportity.app>

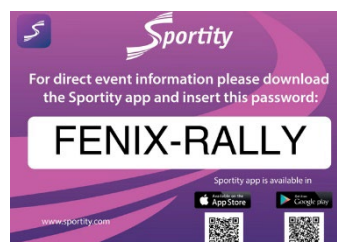

3. PROGRAMME IN CHRONOLOGICAL ORDER AND LOCATION

Oct 29 → Technical check in Genoa and Ferry to Tunis

Oct 30 → Arrival in Tunisia, quick admin check

Oct 31 – Nov 6 → 7 rally legs

Nov 7 → Departure from Tunis

October / November 2025

M	T	W	T	F	S	S
27	28	29	30	31	1	2
3	4	5	6	7	8	9

30th October 2025 - Thursday

Arrival of participants by ferry and self transport to Monastir

Opening of bivouac and Start of the hotel package

13:00 – 15:00 – Administrative check for Tunisian teams

18:00 – 20:00 – Administrative check

22:00–02:00 +1(next day) – Administrative check

30th October 2025 - Thursday

Arrival of participants by ferry and self transport to Monastir

Opening of bivouac and Start of the hotel package

13:00 – 15:00 – Administrative check for Tunisian teams

18:00 – 20:00 – Administrative check

22:00–02:00 +1(next day) – Administrative check

30th October 2025 - Thursday

Arrival of participants by ferry and self transport to Monastir

Opening of bivouac and Start of the hotel package

13:00 – 15:00 – Administrative check for Tunisian teams

18:00 – 20:00 – Administrative check

22:00–02:00 +1(next day) – Administrative check

31th October 2025 – 06th November 2025

7 rally legs

Publication of Preliminary Classifications and Start lists on the Digital Notice Board/Sportity App and on the website

Publication of Final Classification (After the Stewards have declared the Classification final)

06th November Thursday. Prize-giving ceremony

07th November 2025

Friday Hotel check out

4. ENTRIES

4.1. Closing dates for entries

Closing of online Entries | 30 September 2025 (Tuesday) | 23:59h

4.2. Entry procedure

Complies with the RBI Regulations.

By signing/confirming the entry form the Competitor/Crew, its personnel and its accompanying persons submit themselves only to the sporting jurisdictions specified in the RBI Sporting Regulations, as well as the ruling of the following Regulations: Supplementary, Technical and Service, including all appendices.

Admissible drivers and co-drivers are all persons over 16 years of age (the date of the birthday being binding), in possession of a valid driving license for the competition vehicles they want to enter the event.

The organizer reserves the right to refuse the entry to a driver, co-driver, or a service member.

The electronic entry application for the Fenix Rally 2025 is available on the website www.fenix-rally.com

Online entry form must be completely filled out and full entry fees must be paid according to the information specified in these Supplementary Regulations.

IMPORTANT: All necessary information regarding the rally will be sent out exclusively in electronic form by e-mail, and for this reason, each participant has the obligation to make known a current and regularly accessed e-mail address in the course of the registration procedure.

4.3. Number of vehicles accepted and vehicle classes

4.3.1. The number of vehicles shall be limited to: 130

4.3.2. Eligible vehicles

All vehicles must have valid registration and insurance and to be roadworthy for driving on public roads.

All vehicles must comply with the **RBI Technical Regulations**

The rally is for vehicles with valid or expired FIA/FIM homologation or vehicles without FIA/FIM homologation.

Fenix Rally 2025 will have the following categories and classes

“Discovery” is a non-racing category!

CROSS COUNTRY CATEGORY	
Class	subclass
ENDURO	
ATV	
SSV	
CARS	LIMITED

DISCOVERY CATEGORY	
Class	subclass
DISCOVERY	SSV
	CARS

	OPEN
TRUCKS	

Minimum 7 vehicles should be registered in one class in order to make a separate ranking. The organizer has the right to combine or cancel classes and subclasses if the minimum number of crews is not reached.

All vehicles, also the service vehicles and other wheelers, must have a valid registration and insurance.

4.4. Entry fees / entry fee packages

4.4.1. Entry fees for race vehicles

CROSS COUNTRY CATEGORY

	PROMO RATE <i>EXTENDED till 30.07.2025</i>	STANDARD RATE <i>till 15.09.2025</i>
ENDURO	€ 3290	€ 3590
ATV	€ 3290	€ 3590
SSV - 2p	€ 5490	€ 5990
CAR - 2p	€ 5490	€ 5990
TRUCK 2p	€ 6190	€ 6990
TRUCK 2p	€ 7290	€ 7990

For entry requests after the closing date an administrative penalty fee of € 300 must be paid in addition to the Entry fee.

DISCOVERY CATEGORY

	PROMO RATE <i>EXTENDED till 30.07.2025</i>	STANDARD RATE <i>till 15.09.2025</i>

SSV - 2p	€ 5490	€ 5990
CAR - 2p	€ 5490	€ 5990

For entry requests after the closing date an administrative penalty fee of € 300 must be paid in addition to the Entry fee.

For any additional information about the entry fees:

<https://fenix-rally.com/entry-fees-2025/>

Fees include:

- Sporting rights (for competitors only)
- Participation in the event (Administrative checks and scrutineering, prologue and 7 rally days)
- General Third-Party Liability Insurance
- Administrative set
- Safety Tracking System rental (for competitors only)
- IRIS device rental
- Access to rally infrastructure and to service area
- Professional medical assistance – helicopter & medical crew in 4x4 vehicles
- Recovery service (for competitors only)
- Hotel Accommodation in shared room (see art. 16)
- Meals at the bivouac (breakfast, lunch box, dinner) included in the official rally catering
- Personal gift from the FAN SHOP
- Award ceremony

Fees DO NOT include:

- Personal Accident Insurance
- Transport of participants and their vehicles
- Fuel supply
- Personal expenses
- Deposit for Safety Tracking Systems
- Flights
- Ferry
- Food and drinks not included in the official rally catering
- Any medical related costs, incl. COVID-9 (PCR and other tests)
- Single accommodation

4.4.2. Entry fees for Service

Service member / accompanying person	1290 € per person
Service car small	170 € per vehicle
Service bus/van/camper up to 3.5t	190 € per vehicle
Truck over 3.5t	260 € per vehicle

Truck trailer (towed by registered service truck)	Free
Car trailer (towed by registered service car)	Free

*For any additional information about the entry fees:

<https://fenix-rally.com/entry-fees-2025/>

Fees for a crew member include:

- Participation in the event (Administrative checks and scrutineering, 7 rally days)
- General Third-Party Liability Insurance
- Administrative set bracelets, stickers etc.)
- Hotel Accommodation in shared room (see art. 16)
- Meals at the bivouac (breakfast, lunch box, dinner) included in the official rally catering
- Personal gift from the FAN SHOP

Fees DO NOT include:

- Personal Accident Insurance
- Transport of participants and their vehicles
- Fuel supply
- Personal expenses
- Flights
- Ferry
- Food and drinks not included in the official rally catering
- Any medical related costs, incl. COVID-9 (PCR and other tests)
- Single accommodation

Any fault remarked by a judge of fact or member of the Organisation will result in an additional fee of 250 € payable to the Organiser.

4.5. Fees and deposits

Rental fees for the Safety Tracking System (incl. vehicle-to vehicle communication) and the IRIS device are included in the entry fees.

Deposit for Safety Tracking System including the Satellite Emergency Tracking system:

ENDURO & ATV	1000 €
SSV, CARS and TRUCKS	1000 €

Deposit must be paid in cash at the administrative check.

Deposits are refunded when the equipment is brought back in working condition at the end of the rally. Any damage to the equipment must be paid according to the supplier's part list.

4.6. Payment

To validate the registration, every crew must pay at least a Down Payment corresponding to the class in which it is entering and according to the terms of each rate period.

Any entry not accompanied by the entry fee shall be null and void. The down payment is a part of the total amount.

The down payment is not refundable.

4.6.1. PROMO RATE – TERMS AND CONDITIONS

The promotional price is valid for registrations made till July 30, 2025, with payments made in accordance with the specified terms.

Step 1) Down Payment (Non-Refundable). Due immediate upon application/registration

- 1400 EUR for ENDURO and ATV
- 2400 EUR for SSV, Cars and Trucks

Step 2) Second Installment. Deadline: extended till 30th July 2025

- 1000 EUR for Enduro
- 2000 EUR for SSV and Cars
- 3000 EUR for Trucks

Step 3) Third Installment. Deadline: extended till 30th August 2025

- Remaining balance of the entry fee
- Fees for additional people, vehicles and services

Step 4) – Final Installment. Deadline: extended till 30th September 2025

- Fees for additional people, vehicles and services

IMPORTANT: - Decisive is the date of receiving the payment.

4.6.2. STANDAR RATE – TERMS AND CONDITIONS

The standard price is valid for registrations made till September 15, 2025, with payments made in accordance with the specified terms.

Step 1) Down Payment (Non-Refundable). Due immediate upon application/registration

- 3400 EUR for ENDURO and ATV
- 4400 EUR for SSV, Cars and Trucks

Step 2) – Final Installment. Deadline: extended till 30th September 2025

- Remaining balance of the entry fee
- Fees for additional people, vehicles and services

4.6.3. Additional terms and conditions

Payments of the entry fee received after the PROMO RATE OFFER time periods will result in re-calculation of the open amount according to the STANDARD RATE.

No down payment received 2 weeks after the entry of the online registration will result in deleting of the registration.

Prior to the administrative check, the full total amount of the entry must be paid. As a reference participant must enter full name and booking number. The receipt of payment is the decisive date.

IMPORTANT: Participants who pay their entries after the date of the closing of the online entry must show copy/document of the fees paid at the Administrative Check on site.

Entries after the closing date of the online entry may be accepted with the approval of the Rally Administration. Please contact Rally Administration. In this case the entry application will be validated at the Administrative Check only if accompanied by the total amount of the entry fee (valid for that period) paid on site.

For entry requests after the closing date an administrative penalty fee of € 300 must be paid in addition to the Entry fee.

IMPORTANT: NO BANK CHEQUES WILL BE ACCEPTED!

IMPORTANT: All Bank Charges incurred must be paid by the sender.

IMPORTANT: THE ORGANIZER RESERVES THE RIGHT NOT TO VALIDATE REGISTRATIONS OF ENTRANTS:

- Which have not paid the down payment (deposit) within 2 weeks after submitting the online registration; In this case the online entry will be deleted.
- Who have not fully paid the total amount of the entry fee by the time of the administrative check as specified in the supplementary regulations.
- Entry requests after the closing date of the online registration may be accepted with the approval of the Rally Administration. In this case, contact Rally Administration.

The entry application will be validated at the Administrative Check only if accompanied by:

- Online entry confirmation incl. booking number or entry confirmation by email from the Rally Administration.
- Payment of full amount of the entry fee or copy/document for the fees paid.
- The required documents as per these regulations

All vehicles, also the service vehicles and other wheelers, must have a valid registration and insurance.

4.6.4. Allocation of start numbers

Allocation of start numbers will be done according to the “first come, first served principle.”

Reservation of start numbers will be done once the down payment has been received. Start numbers will be confirmed once the full payment of the entry fee has been received.

4.7. Invoicing

Invoices will be issued after receiving the payment in our bank account until the end of the running month.

Issued invoices will be uploaded in the competitor’s/crew’s account in online registration tool until the 15th of the following month (month after the receiving of payment).

Invoices will include the data from the section “Billing” in the rally account in the RBI online tool.

The mandatory details for issuing the invoice are:

- a. Full name of the company or the person
- b. Full address (street, city, country)
- c. VAT number – (Please fill the correct VAT number if your company has a valid VAT number for European Union (EU). It is possible this VAT number for EU to be different from your local/national number)

Explanation VAT:

- VAT number refers to a number used to identify a company that conducts business in areas over which the European Union has taxation authority.
- All VAT numbers begin with an identifier code that indicates the country that issued the number.
- In the EU, a VAT identification number can be verified online at https://ec.europa.eu/taxation_customs/vies/?locale=en
- It confirms that the number is currently allocated and can provide the name or other identifying details of the entity to whom the identifier has been allocated.

IMPORTANT: The participants have to fill in the section “Details for invoice” when creating an account in the online tool. It is not possible to update this section once the account has been created. If you have to change the details, please contact: info@rallye-breslau.com

After issuing the invoice no changes are possible anymore.

All the payments will be updated in the Online Registration Tool after the payment has been received in our bank account.

The registered participants can check their balance in the online registration tool using their user name, password and booking number.

4.8. Cancellation and entry fee refunds

If a competitor cancels an entry or fails to make payment by the due dates, the following refund policy will apply:

- For withdrawals on or before 30 July 2025, the down payment will be retained to cover administrative and organizational costs.
- For withdrawals between 1 August 2025 and 15 September 2025, 50% of fees already paid will be refunded; however, the down payment will still be retained.
- For withdrawals after 15 September 2025, no refunds will be issued.

Cancellations and requests for refunds, transfer of payment to substitute participants must be sent in written form to the Rally Administration.

Refunds will be made by 1.12.2025 at latest.

5. INSURANCE COVER

Complies with RBI Sporting Regulations.

The Organization has subscribed a General Third-Party Liability insurance policy for sporting event in accordance with the running legislation.

For Fenix Rally 2025 the insurance cover extends to the statutory liability:

The insurer's maximum compensation:

- for personal injury, property damage and financial loss is 5.000.000 EUR;
- for bodily injury is 31.000,00 EUR limit for a single person;
- in case of death 15.500,00 EUR for a single person;

This contract assures financial coverage of damages caused to third parties by the Organizer or by the competitors. This insurance gets into effect from 28.10.2025 (Tuesday) at 00:00h till 07.11.2025 (Friday) at 23:59h.

This insurance coverage applies only to the Selective Sections of the itinerary, run for best time, achieving the maximum speed. It begins already from entering the Control Zone (yellow sign "notice time control") at the start of a Selective Section and ends with the end of the Control Zone (beige sign "control zone end") at the finish of the Selective Section.

The Organization has subscribed an insurance policy with:

SRC Special Risk Consortium GmbH
Belforstr. 15
50668 Köln, Germany
Phone: +49 221 91409-40
<https://www.src-net.de/>

6. ADVERTISING AND IDENTIFICATION

Complies with RBI Sporting Regulations.

See **Appendix 3** of these Supplementary Regulations.

7. TECHNICAL REQUIREMENTS

The rally complies with RBI Technical Regulations.

The overall technical requirements are a combination of the following:

- The General Technical Regulations
- The Specific Technical Regulations for the vehicle / category
- The Specific Safety Requirements for the vehicle / category
- Additional Specific safety requirements listed in the Supplementary regulations for the event

The combination of all those makes the overall technical regulation for the competing vehicles.

Vehicles must have valid road registration and insurance, together with Green Card Certificate, valid for Tunisia and to be roadworthy for driving on public roads.

The rally does not require FIA or FIM homologation / technical passport of the racing vehicles. Never the less such can help speeding up the scrutineering. There are however several safety and technical requirements which must be fulfilled before entering the scrutineering.

All vehicles must have all their registration plates secured to the vehicles.

8. FUEL

6.1. General

Complies with RBI Sporting Regulations

6.2. Refuelling in the Remote Service zones

Refueling options:

- **Commercial fuel stations** (note: most require **cash payment** – please carry cash).
- **By your service crew** at remote service/refuel zones (available on **Legs 2–5**).
- **By the organization (ORGA)** – for **moto and quad** competitors only.

Maximum distances between refuels:

- **Moto and Quad:** ~150 km
- **SSV, Car, Truck:** ~175 km

WARNING: Under no circumstances service is allowed on the rally track and in the vicinity of the RZs. Refuelling by the service or with fuel brought by the service is considered an unauthorized service and will be penalized as per the regulations.

9. ADMINISTRATIVE CHECKS

The Administrative Check for Fenix Rally is completed in two phases:

- **Online Administrative Check (before the rally)**
- **Final Check on-site in Monastir**

Online Check

All competitors must complete the online entry and upload the required documents no later than 3 October 2025. Once the Rally Office verifies and approves the documents, a green check mark will appear under the document section in the entry form.

Payments

All fees and guarantees must be settled by **20 October 2025** (Tunisian teams by 30 October in Monastir). On-site payments can be made in cash only and in EUR.

3. Final Administrative Check – Monastir

On-site in Monastir, competitors submit their signed documents to the Rally Office:

- Self-check list for the vehicle
- Waiver forms for Driver & Co-driver(s)
- Waiver forms for Team Members
- Copy of missing or unapproved documents.

Documents cannot be copied or uploaded on-site, and submissions by email or WhatsApp will not be accepted

Once verification is complete, they receive:

- Start Permission sticker
- SOS sticker
- Tracking equipment
- SIM cards

📍 Opening hours – Rally Office (Monastir):

30/10: 13:00–15:00 (Tunisian teams only)

30/10: 18:00–20:00

30/10: 22:00–02:00 (+1)

31/10: 06:00–08:00

Missing deadlines or documents will result in a €200 fee.

Any Competitor who has a serious medical history that may lead to problems during the rally must meet the Chief Medical Officer at the administrative checks to provide them with all these details in a fully confidential way. Thus, they will be able to update a list of participants who required monitoring during the event.

It is not authorized for the Competitor to come and go from the Administrative Checks; their complete process must be done in one time.

7. SCRUTINEERING

7.1. General

All rally vehicles must comply with the **RBI Technical regulations**.

The act of presenting a vehicle for Scrutineering is considered an implicit statement of conformity. Scrutineering carried out before the start of the rally will be of a general nature to ensure general conformity with the Category and Classes entered, essential safety items are carried and conformity with the national Traffic Law.

7.2. SELF CHECK

To simplify and speed up the scrutineering process, competitors were required to carry out a self-check at home before travelling. Each crew that confirmed its entry received an official scrutineering checklist from the organizer, along with vehicle stickers and mounting kits for the rally safety system.

The scrutineering self-checklist must be completed and signed as a declaration that the vehicle complies with all sporting, technical, and safety regulations of the event.

7.3. MANDATORY VEHICLE PHOTOS

All competitors must submit four (4) photos of their rally vehicle by the deadline.

Take clear photos of the rally vehicle showing:

- Front view
- Rear view
- Left side view
- Right side view

The photos must clearly show the vehicle with all equipment exactly as it will compete in the rally. Photos taken from long distance, at unusual angles, or where details cannot be inspected will not be accepted.

Send the photos by email

Email: tech@fenix-rally.com

Subject: Start number **XXX** (replace "XXX" with your start number, e.g., "456")

Deadline: 26 October 2025

Please note: this email address is only for submitting scrutineering photos. Do not send questions—messages will not be answered.

Penalty:

Failure to provide correct photos by the deadline will result in a 5-minute sporting penalty applied to Leg 1 of the rally.

7.4. ORGANIZER CONFORMITY CHECKS

Port of Genoa (before ferry departure to Tunis):

Vehicles travelling on the organizer's main ferry connection will undergo conformity checks at the port. Vehicles will not be unloaded, but crews must cooperate fully and facilitate access for the scrutineers.

Other ferry connections or vehicles already in Tunisia:

Vehicles arriving via different routes, or already based in Tunisia, will be checked in **Monastir** at the first bivouac during designated opening hours.

Important notes:

The competitor remains fully responsible for the eligibility, conformity, and safety of their vehicle at all times.

The organizer and officials may carry out additional spot checks or re-inspections at any stage of the rally.

Cooperation during conformity checks is mandatory to ensure safety and fairness for all participants.

7.5. VEHICLE READINESS

Every rally vehicle must be **100% rally-ready before being loaded for transport to Tunisia.**

All official **stickers must be applied** according to the sticker plan.

All required **brackets for navigation, tracking, and safety equipment must be mounted** in the correct places as per the installation instructions.

⚠ There will be **no preparation time in Monastir.** Vehicles must arrive fully ready to start the competition.

Teams from Tunisia and non-European countries will collect their stickers and mountings at **Rally HQ in Monastir on 30.10.2025 from 13:00 till 15:00 hrs.**

7.6. Scrutineering, mandatory documents

All documents supplied by the organization at the administrative check. SOS / OK Board – (DIN A3 Format) – Mandatory for all competitors to be printed out by themselves and be available.

7.7. Survival equipment

During Scrutineering, crews must present the required Specific Safety and survival equipment as per **Appendix 2.**

7.8. Mud flaps (excerpt RBI Technical regulations)

It is highly recommended for all Cross country category vehicles – SSV, CAR, TRUCK: Mud flaps, covering at least 50% of the wheels (centre of the wheel hub) on the back of all wheels.

7.9. Windows/Nets (excerpt RBI Technical regulations)

Vehicles with no doors or door windows must have window nets installed. The nets must cover at least 70% of the opening and be readily opened from the top or bottom, from inside and outside the vehicle. The net's mesh size must be no greater than 50mm x 50mm or FIA homologated / expired homologation.

7.10. Stop lights (excerpt RBI Technical regulations) (not required for Discovery category)

SSV, Cars and Trucks: Additional 2 stop lights located separately, minimum 0.75m apart, or 1 additional “big” stop light located in the centre, in the upper third of the vehicle, minimum 1.25 meters from the ground, shining to the rear (standard 2 + 1 or 2 additional). Must be visible from the car behind.

7.11. Installation of Safety Tracking System

It is compulsory for the Crews to equip their vehicles with Safety Tracking System, for active monitoring and communication with all competing vehicles. The Geotraq Rally Safety System includes live tracking, route & velocity recording and Vehicle-to-vehicle communication.

Geotraq Rally Safety System units will be delivered at the administrative check.

The equipment must be installed by the competitors following the “Geotraq Self-installation manual”.

The system will be checked during scrutineering for proper installation and operation.

Competitor/Crew, who during scrutineering presents damaged / non-properly mounted / non-operating wires, is obliged to remove the damage and / or failure before the end of Scrutineering.

Any Crew with a vehicle without properly mounted and fully operational GPS Tracking safety system unit, will not be authorized to start.

The rental fee of the Geotraq Rally Safety System unit is included in the entry fee. A deposit must be paid at the administrative check. Installation and operation manuals are published in appendix of these Regulations.

7.12. Satellite Emergency Tracking System

Each crew/rider will use the Satellite Emergency Tracking device together with the Geotraq Rally Safety System.

The rental of the device is included in the entry fee.

The deposit for the rental devices – See art. 4.5 “Fees and Deposits”.

7.13. Navigation System (NAV-GPS) and digital road book

CROSS COUNTRY – ALL CLASSES

The participant in all classes will drive with **IRIS Digital Road Book**.

The Organizer will provide IRIS Digital Road Book and GPS navigation system, incl. mounting kit, Satellite Tracking System and Rally Safety System.

Discovery

Garmin Device, incl. mounting kit, Satellite Tracking System and Rally Safety System.

GUARANTEE / DEPOSITS

for the equipment provided by the Organizer.

A refundable guarantee deposit of € 1000 against loss and damage of the rally equipment must be paid.

The Guarantee must be paid via separate bank transfer with reference “Guarantee for rally equipment for booking number XXXXX” to the same bank account as for the entry fee.

Any damage to the equipment must be paid according to the supplier’s part list.

The deposit will be refunded by wire transfer up to 2 weeks after the rally, provided the equipment is returned in full and in working condition.

7.14. Electronic equipment

Complies with art. 7 of the RBI Sporting regulations.

8. OTHER PROCEDURE AND REGULATIONS

8.1. General

Complies with RBI Sporting Regulations

8.2. Driver’s briefings

At the briefings prior to each Leg of the event, the participation of at least one crew member is compulsory.

A briefing may be substituted by communication of written briefing notes on the DNB and/or broadcasted through the communication channels between the organizer and competitors.

8.3. Road Sections and Selective Sections

The route of the Rally is composed of Road Sections with a targeted driving time, open for road traffic, and Selective Sections on roads/areas open for the traffic.

8.4. Reconnaissance

As from the publication of the Supplementary Regulations, the presence of a competitor, or anyone connected with a competitor, on any part of the itinerary of an event is prohibited.

8.5. Re-start after retirement (excerpt RBI Sporting Regulations)

Any crew which has failed to complete a Selective Section will be assumed to Re-start the event from the start of the next Leg, unless they confirm otherwise in writing to the Clerk of the Course.

The crew may nevertheless be allowed to Re-start from the next Selective Section after approval from the Clerk of the Course following their due times and maximum permitted lateness.

This shall apply to any vehicle which has not been classified on the grounds of exceeding the time limit or has failed to report to a control, but shall not apply where the vehicle has been disqualified for breach of eligibility requirements, traffic infringements or by a decision of the Stewards.

8.6. Check-in procedure (excerpt RBI Sporting Regulations)

Complies with RBI Sporting Regulations

Any difference between the actual check-in time and the target check-in time shall be penalized as follows:

- For late arrival: 10 seconds per minute or fraction of a minute
- For early arrival: 1 minute per minute or fraction of a minute

8.7. Permitted early check-in (excerpt RBI Sporting Regulations)

At the time control at the end of a leg, crews are authorized to check-in ahead of the time without incurring a penalty.

Additional time controls with permitted early check-in will be published in the itinerary.

8.8. Maximum permitted lateness at a TC (excerpt RBI Sporting Regulations)

At a Time Control, any lateness exceeding 30 minutes of any individual target time will result in the competitor concerned being considered to have retired at that control, and the competitor will receive a Fixed Penalty. If this occurs at the last Time Control of a leg, the competitor will be penalized with a missed TC only. In calculating such lateness time, the actual time and not the penalty time (10 seconds per minute) applies. The crew may nevertheless re-start the rally under the provisions specified in these regulations.

8.9. Maximum permitted lateness at a PC and Finish of Selective Section (excerpt RBI Sporting Regulations)

At a Passage Control or finish of a Selective Section, any lateness exceeding the maximum permitted lateness (MPL) will result in the competitor concerned being considered to have retired, and the competitor will receive a Fixed Penalty. The crew may nevertheless re-start the rally under the provisions specified in these regulations.

8.10. Official time and distance used during the rally

The official time of the rally is the GPS time at the place where the rally is held.

The time measurement accuracy of the Selective Section is 1 second.

The official distance calibration is a nominal kilometer measured by a GPS device.

8.11. Procedure at the start of a Selective Section (excerpt RBI Sporting Regulations)

Complies with RBI Sporting Regulations

At each Start, there will be electronic starting device with green light. The device may be coupled with a photocell responsible for detection of false starts. The photocell will be placed about 50 cm beyond the start line.

The display will be placed so to be well visible to a Crew sitting in a vehicle on the starting line.

The vehicle with the Crew is placed at the start line. The starting device continuously counts down the last 10 seconds to the moment of the green light. Numbers are shown in the sequence: 10, 9, 8, 7, 6, 5, 4, 3, 2, 1 and the green light. The green light will stay on for 5 seconds. Within 20 seconds from the start of the green light, the Crew must start.

8.12. Maximum permitted speed

Maximum permitted speed for ALL classes in the rally will be 170 km/h.

9. OTHER PROCEDURES

9.1. Bivouac control

The bivouac is a closed area, checked and secured, reserved for private use during the rally, whose access is exclusively and uniquely for persons who have been accredited and registered by the Organization, as well as representatives of local public authorities.

Not registered participant and/or vehicles must pay a deposit of 1000 € at the camp control in the bivouac. The deposit is refundable upon registration and payment of full entry fees at the Administrative Check.

Cash penalty for not registered persons caught by the control afterwards is 1000 € per person. In addition, the Stewards will be informed for further sporting penalties for the Competitor/Crew concerned.

9.2. Environmental protection

All the Competitors/Crews, members of their personnel and their accompanying persons are required to observe the Environmental rules and especially use protective sheets against the destruction and pollution of the ground surface with petroleum materials.

Any maintenance work without the required protective sheet under the vehicle found by the Organizer, would entail the imposition of a fine up to 100% of required entry fee or other penalties by decision of the Stewards.

9.3. Toll collection in Tunisia

Highway A1 tolls can only be paid in cash in Tunisian Dinars. Arriving in Tunisia you must exchange Tunisian Dinars for this payment at local Banks or ATMs in the city of TUNIS.

9.4. COVID-19 protocol

Any update on the Covid-19 protocols indicated by the authorities of Tunisia will be communicated by means of a Bulletin.

The Organization will not be responsible for Covid19 infections that may occur during the FENIX RALLY 2025. Each Participant personally assumes the risks linked to Covid19 by traveling to and participating in an event of this type and exonerates the organization of any medical situation that may arise from their participation.

9.5. Image Right

Each of the Event Participant acknowledges that their participation in the Event authorizes the Organiser and its assignees or other qualified parties to capture and retain, on any medium and by any means, and to subsequently reproduce and represent, without remuneration of any kind, their first and last name, voice, image, biography and more generally their sports performance within the framework of the Event as well as the trademark(s) of their equipment manufacturers and sponsors in any form, on any existing or future medium, in any format, for any communication to the public throughout the world, for any use including for advertising and/or commercial purposes and for no other limitations than those indicated below.

The Organiser and its assignees or other qualified parties may exploit the fixed or audio-visual images of the Event for any use other than for advertising and/or commercial purposes – and the promotion of the Event is not regarded as an advertising or commercial exploitation - for the period of protection currently granted to these types of use under intellectual property legislative and regulatory provisions, the judicial and/or arbitration decisions of all countries, and current or future international conventions, including for possible extensions that could be made to this duration.

The Organiser, when authorising an assignee to use images of the Event for advertising or promotional purposes, shall limit the exploitation duration granted to 10 (ten) years following the date of the annual of the Event concerned.

RBI Sport is the sole owner of all the Fenix Rally commercial rights.

As such, the Organiser has full and exclusive ownership of all the images and audio captured during the Event, on the route and also in all areas under the Organiser's control: Departure-arrival areas, bivouac, parc fermé, service park, interview areas, protocol podiums, technical and administrative checking areas, etc.

Consequently, except with the prior written consent of RBI Sport the capture and/or broadcast (on any medium whatsoever) of any images and/or sounds from the Event and/or any protected area by any person subject to the Regulations is not permitted.

As and when required, it is specified that capturing images and/or audio of the Event and/or the Protected Areas for broadcast live or at a later date via mobile app (e.g. Facebook, etc.) is strictly prohibited, except with the Organiser's prior written consent.

10. PRIZES

10.1. Location

The prize giving ceremony will take place in the bivouac. All members of the Competitor/ Crew shall be present at the prize-giving. Crews who are not present at the prize-giving may forfeit their prizes; however, the final classification will not be modified.

10.2. Winner Trophies will be awarded to the winners in the following Overall Classifications:

- ENDURO class – 1st, 2nd and 3rd place
- ATV class – 1st, 2nd and 3rd place
- SSV class – 1st, 2nd and 3rd place
- CARS LIMITED – 1st, 2nd and 3rd place
- CARS OPEN – 1st, 2nd and 3rd place
- TRUCKS - 1st, 2nd and 3rd place

Minimum 7 vehicles should be registered in one class in order to make a separate classification for this class.

11. PROTESTS

Complies with RBI Sporting Regulations.

The fee for a protest is 1000 EUR, paid in cash together with the lodging of the protest.

Protests cannot be lodged after the first competitor/crew has left to the course for the next Leg.

Protest for the last rally Leg cannot be lodged after 30 min of publishing the provisional classification.

The Steward's decisions are final and cannot be appealed.

12. CATERING

The Entry includes catering services. Catering starts with the **dinner on Thursday evening 30.10.2025**, and ends with a **breakfast on Friday morning 07.11.2025**.

IMPORTANT: The catering **doesn't include drinks**, except coffee and tea at breakfast. **Water in bottles will be distributed by** the Organizer **free of charge** at the bivouac and at the Time Controls of the Selective Sections.

13. HOTEL and TENTED BIVOUAC ACCOMMODATION

The entry fee for crews and service members includes hotel accommodation as following:

- 8 nights in a shared double, twin room or triple room at 4-star hotels
- Half board terms
- Check in 30.10.2025 (Thursday), check out 07.11.2025 (Friday)

If the hotel doesn't offer type of rooms suitable to the number of the participants in the team then automatically single upgrade will be applied for the period of the stay in this hotel.

For single room upgrades, additional nights before and after the rally, please contact the Rally Administration.

Appendix 1 - PRELIMINARY ITINERARY

		FENIX RALLY 2025 Preliminary itinerary							
Leg 1		Longest distance between refueling: 136 km				31.10.2025 (Friday)			
TC	LOCATION	SS dist.	Liaison dist.	Total dist.	Target time	First bike due	First car due	Est. time	Max. time
TC 0	Bivouac 1 OUT Monastir					9:30	10:01		
TC 1	SS 1 START		40.50	40.50	1:00	10:30	11:01		
DSS 1	SELECTIVE SECTION 1 START				(00:03)	10:33	11:04	2:30	5:00
ASS 1	SELECTIVE SECTION 1 FINISH	104.59		145.09		(13:03)	(13:34)		
TC 1A	Bivouac 2 IN Tozeur (e)		249.73	394.82	5:00	(18:03)	(18:34)		
Friday totals		104.59	290.23	394.82		Sunrise: 6:38	Sunset: 17:35		
(e) Early Check-in is permitted distance is in KM.						SAFETY CUT-OFF HOUR: 21:00			

Leg 2		Longest distance between refueling: 144 km				1.11.2025 (Saturday)			
TC	LOCATION	SS dist.	Liaison dist.	Total dist.	Target time	First bike due	First car due	Est. time	Max. time
TC 1B	Bivouac 2 OUT Tozeur					7:30	8:01		
TC 2	SS 2 START		4.23	4.23	0:05	7:35	8:06		
DSS 2A	SELECTIVE SECTION 2A START				(00:03)	7:38	8:09	0:40	1:30
ASS 2A	SELECTIVE SECTION 2A FINISH	41.60		45.83		(08:18)	(08:49)		
NZ	Neutralization with Refueling			(57.83)					
TC 3	SS 2B START		23.71	69.54	0:45	9:03	9:34		
DSS 2B	SELECTIVE SECTION 2B START				(00:03)	9:06	9:37	1:54	4:00
ASS 2B	SELECTIVE SECTION 2B FINISH	117.82		187.36		(11:00)	(11:31)		
NZ	Neutralization								
RS	Remote Service EL FAOUAR			(195.10)		Service time included in the Neutralization			
TC 4	SS 2C START		74.85	262.21	2:00	13:00	13:31		
DSS 2C	SELECTIVE SECTION 2C START				(00:03)	13:03	13:34	0:58	2:00
ASS 2C	SELECTIVE SECTION 2C FINISH	60.10		322.31		(14:01)	(14:32)		
TC 4A	Bivouac 3 IN Douz (e)		10.74	333.05	0:10	(14:11)	(14:42)		
Saturday totals		219.52	113.53	333.05		Sunrise: 6:45	Sunset: 17:32		
(e) Early Check-in is permitted distance is in KM.						SAFETY CUT-OFF HOUR: 19:30			

Leg 3		Longest distance between refueling: 146 km				2.11.2025 (Sunday)				
TC	LOCATION	SS dist.	Liaison dist.	Total dist.	Target time	First bike due	First car due	Est. time	Max. time	
TC 4B	Bivouac 3 OUT Douz					7:00	7:31			
TC 5	SS 3A START		35.36	35.36	0:35	7:35	8:06			
DSS 3A	SELECTIVE SECTION 3A START				(00:03)	7:38	8:09	0:46	1:30	
ASS 3A	SELECTIVE SECTION 3A FINISH	47.99		83.35		(08:24)	(08:55)			
NZ	Neutralization with Refueling			(88.97)						
RS	Remote Service KSAR GHILANE 1			(88.97)	Service time included in the Neutralization					
TC 6	SS 3B START		6.65	90.00	0:40	9:04	9:35			
DSS 3B	SELECTIVE SECTION 3B START				(00:03)	9:07	9:38	3:06	5:30	
ASS 3B	SELECTIVE SECTION 3B FINISH	124.17		214.17		(12:13)	(12:44)			
NZ	Neutralization			(215.22)	Service time included in the Neutralization					
RS	Remote Service KSAR GHILANE 2			(215.22)	Service time included in the Neutralization					
RZ	Top-up Refuel 5L (Only for ENDURO, Optional)			(237.30)						
TC 7	SS 3C START		23.24	237.41	1:00	13:13	13:44			
DSS 3C	SELECTIVE SECTION 3C START				(00:03)	13:16	13:47	2:10	4:00	
ASS 3C	SELECTIVE SECTION 3C FINISH	134.72		372.13		(15:26)	(15:57)			
RZ	Refueling Zone (Only for ENDURO, ATV)									
TC 7A	Bivouac 3 IN Douz (e)		11.59	383.72	0:10	(15:36)	(16:07)			
Sunday totals		306.88	76.84	383.72		Sunrise: 6:44	Sunset: 17:31			

(e) Early Check-in is permitted distance is in KM. SAFETY CUT-OFF HOUR: 20:30

Leg 4		Longest distance between refueling: 163 km				3.11.2025 (Monday)				
TC	LOCATION	SS dist.	Liaison dist.	Total dist.	Target time	First bike due	First car due	Est. time	Max. time	
TC 7B	Bivouac 3 OUT Douz					6:30	7:01			
TC 8	SS 3A START		11.50	11.50	0:15	6:45	7:16			
DSS 4A	SELECTIVE SECTION 4A START				(00:03)	6:48	7:19	2:25	5:00	
ASS 4A	SELECTIVE SECTION 4A FINISH	150.75		162.25		(09:13)	(09:44)			
RZ	Top-up Refuel 5L (Only for ENDURO, Optional)			(162.55)						
NZ	Neutralization with Refueling			(184.38)						
RS	Remote Service KSAR GHILANE 1			(184.38)	Service time included in the Neutralization					
TC 9	SS 3B START		22.99	185.24	1:00	10:13	10:44			
DSS 4B	SELECTIVE SECTION 4B START				(00:03)	10:16	10:47	4:04	7:30	
RZ	Refueling Zone (For ALL Classes)	84.12		(269.36)						
ASS 4B	SELECTIVE SECTION 4B FINISH	231.94		417.18		(14:20)	(14:51)			
TC 9A	Bivouac 3 IN Douz (e)		146.22	563.40	1:45	(16:05)	(16:36)			
Monday totals		382.69	180.71	563.40		Sunrise: 6:44	Sunset: 17:30			

(e) Early Check-in is permitted distance is in KM. SAFETY CUT-OFF HOUR: 20:30

Leg 5		Longest distance between refueling: 137 km				4.11.2025 (Tuesday)				
TC	LOCATION	SS dist.	Liaison dist.	Total dist.	Target time	First bike due	First car due	Est. time	Max. time	
TC 9B	Bivouac 3 OUT Douz					7:00	7:31			
RZ	Refueling Zone (Only for ENDURO)	44.96		(44.96)						
TC 10	SS 5 START		51.96	51.96	1:04	8:04	8:35			
DSS 5A	SELECTIVE SECTION 5A START				(00:03)	8:07	8:38	3:04	6:30	
ASS 5A	SELECTIVE SECTION 5A FINISH	129.32		181.28		(11:11)	(11:42)			
NZ	Neutralization with Refueling			(181.54)						
RS	Remote Service CAFE LA TENTE			(181.54)	Service time included in the Neutralization					
TC 11	SS 5B START		18.61	199.89	1:00	12:11	12:42			
DSS 5B	SELECTIVE SECTION 5B START				(00:03)	12:14	12:45	1:45	3:20	
ASS 5B	SELECTIVE SECTION 5B FINISH	59.77		259.66		(13:59)	(14:30)			
TC 11A	Bivouac 3 IN Douz (e)		45.41	305.07	0:40	(14:39)	(15:10)			
Tuesday totals		189.09	115.98	305.07		Sunrise: 6:45	Sunset: 17:29			

(e) Early Check-in is permitted distance is in KM. SAFETY CUT-OFF HOUR: 19:00

Leg 6		Longest distance between refueling: 138 km				5.11.2025 (Wednesday)				
TC	LOCATION	SS dist.	Liaison dist.	Total dist.	Target time	First bike due	First car due	Est. time	Max. time	
TC 11B	Bivouac 3 OUT Douz					6:30	7:01			
TC 12	SS 6A START		47.94	47.94	0:50	7:20	7:51			
DSS 6A	SELECTIVE SECTION 6A START				(00:03)	7:23	7:54	2:00	4:00	
ASS 6A	SELECTIVE SECTION 6A FINISH	126.16		174.10		(09:23)	(09:54)			
RZ	Top-up Refuel 5L (Only for ENDURO, Optional)			(174.11)						
NZ	Neutralization with Refueling at Multiple Commercial Fuel Stations									
TC 13	SS 6B START		189.67	363.77	3:45	13:08	13:39			
DSS 6B	SELECTIVE SECTION 6B START				(00:03)	13:11	13:42	0:39	1:30	
ASS 6B	SELECTIVE SECTION 6B FINISH	41.11		404.88		(13:50)	(14:21)			
TC 13A	Bivouac 4 IN Monastir (e)		42.19	447.07	0:40	(14:30)	(15:01)			
Wednesday totals		167.27	279.80	447.07		Sunrise: 6:46	Sunset: 17:17			

(e) Early Check-in is permitted
distance is in KM.

SAFETY CUT-OFF HOUR: 20:30

SECTION 6

Leg 7		Longest distance between refueling: 106 km				6.11.2025 (Wednesday)				
TC	LOCATION	SS dist.	Liaison dist.	Total dist.	Target time	First bike due	First car due	Est. time	Max. time	
TC 13B	Bivouac 4 OUT Monastir					7:30	8:01			
TC 14	SS 7A START		129.20	129.20	2:20	9:50	10:21			
DSS 7A	SELECTIVE SECTION 7A START				(00:03)	9:53	10:24	0:38	1:30	
ASS 7A	SELECTIVE SECTION 7A FINISH	26.74		155.94		(10:31)	(11:02)			
NZ	Neutralization with Refueling at Multiple Commercial Fuel Stations									
TC 15	SS 7B START		61.35	217.29	1:20	11:51	12:22			
DSS 7B	SELECTIVE SECTION 7B START				(00:03)	11:54	12:25	0:20	0:40	
ASS 7B	SELECTIVE SECTION 7B FINISH	21.27		238.56		(12:14)	(12:45)			
NZ	Neutralization									
TC 16	SS 7C START		15.96	254.52	0:20	12:34	13:05			
DSS 7C	SELECTIVE SECTION 7C START				(00:03)	12:37	13:08	0:39	1:30	
ASS 7C	SELECTIVE SECTION 7C FINISH	41.11		295.63		(13:16)	(13:47)			
TC 16A	Bivouac 4 IN Monastir (e)		42.99	338.62	0:40	(13:56)	(14:27)			
Thursday totals		89.12	249.50	338.62		Sunrise: 6:43	Sunset: 17:16			

(e) Early Check-in is permitted
distance is in KM.

SAFETY CUT-OFF HOUR: 19:00

SECTION 7

Appendix 2 - SPECIFIC SAFETY AND SURVIVAL EQUIPMENT

1. Medical kits

Each vehicle must have on board a complete and up-to-date First Aid Kit, compliant with DIN 13164 (for European Travel) with the following but not limiting medical items:

- Dressings
- Bandages
- First Aid Compress
- Emergency Blanket
- Plasters
- Gloves
- Tape
- Scissors
- Information Sheet
- Emergency Procedure Sheet
- Cleansing wipe
- **SUNSCREEN – NOT INCLUDED IN THE FIRST AID KITS**



2. Rescue sheet

Each crew member on board must have a separate Rescue sheet - aluminum blanket minimum 160 cm x 210 cm, which can also be used to signal using the sun.



3. Survival kit

There is no guarantee for an immediate recovery in case of a technical problem. Crew members must be prepared to stay in the desert for minimum one day and night in temperatures below 5 degrees. The following equipment is mandatory to be carried on board the competition vehicle and will be checked at each Leg start for compliance:

- Minimum 3 liters (1.5 liters for Enduro and ATV) of non-alcoholic beverages per person on board. Preferably split between camelback tubes for drinking during the race and bottles.
- Survival food supplies, minimum 1000 calories per person (e.g. Power Bar or similar)
- 1 x safety flashlight/headlamp/flashing torch, recommended over 1000 lumens, with extra batteries
- Warm clothes or sleeping bag
- 2x Lighter
- SSV, CARS, TRUCKS only: A reserve of 5 liters of drinking water in a container or separate bottles, which must be easily accessible without using any tools.
- SSV, CARS, TRUCKS only: 1 x hand shovel.
- Goggles (Motorcycle/Ski) for each crew member.

4. Start refusal

Any crew that fails to bring a medical kit (Art. 1), Rescue sheets (Art.2) and the survival kit (Art. 3) as required by the Supplementary Regulations, will be refused to start the leg until the kits are in conformity with the regulation. RBI Sporting Regulations Article 28.2 (Maximum lateness at the start of a Leg) will apply. In any case the crew will be reported to Stewards to apply a penalty at their discretion.

Images for reference only:



Appendix 3 - VEHICLE IDENTIFICATION AND ADVERTISING

Door/side panels

The Organizer shall supply each crew with a set of Number and "Rally" plates bearing the rally numbers as shown below.

Number plate sizes:

- Motorcycles and ATV vehicles – 2 plates measuring 15x14cm
- SSV – 2 plates measuring 30x28cm
- Cars – 2 plates measuring 42x40cm
- Trucks – 2 plates measuring 50x47cm

Number Roof panel:

For SSV, Cars and Trucks, one roof panel, 42 cm wide by 40 cm high, to be placed on the roof with the top towards the front of the car.

"Rally" plate:

- Motorcycles and ATV vehicles – 1 plate measuring 19x18cm
- SSV – 1 plate measuring 42x22cm
- Cars – 2 plates measuring 42x22cm
- Trucks – 2 plates measuring 42x22cm

Sun visors (only for SSV, Cars and Trucks):

The Organizer shall supply each crew with a 1 sun visor – measuring 180x8cm

Sticker plan: throughout the duration of the rally, the plates must be affixed according to the sticker plan. In no case may they cover, even partially, the vehicle's license plates.

Cleaning the identification plates:

The crews are obligated to present their vehicle at the first Time Control of each Leg with clean identification plates. Any crew not following this rule will be refused to start and will be reported to the Clerk of the Course for further penalties.

Names and flags:

It is recommended to affix the names of the 1st driver and his co-driver(s), plus their national flags, of a height of 30 - 50 mm on both sides of the front wings or front doors of the vehicle.

Obligatory advertising plates:

The stickerage space reserved for the Organizers obligatory advertising and start numbers are described in the official Sticker Plan that is under no exceptions compulsory for all the participants in the rally (crews, service and press).

- Motorcycles and ATV vehicles – 2 plates measuring 12x8cm plus 2 plates measuring 12x12cm
- SSV – 2 plates measuring 30x28cm
- Cars – 2 plates measuring 42x40cm
- Trucks – 2 plates measuring 50x47cm

Preliminary Sticker plan:

ENDURO

- 1 Number plate stickers at the front and to be affixed on the lateral sides of the vehicle
15cm (width) x 14cm (height)- 3 pcs
- 2 Collective advertising plates to be affixed on the lateral sides of the vehicle
12cm (width) x 12cm (height) - 2 pcs
- 3 Rally plate to be affixed on the front side of the vehicle
10cm (width) x 8cm (height)- 1 pcs

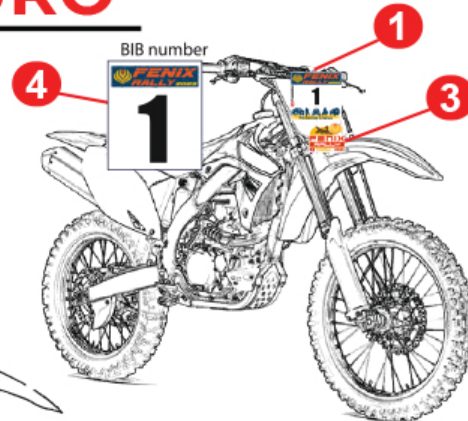
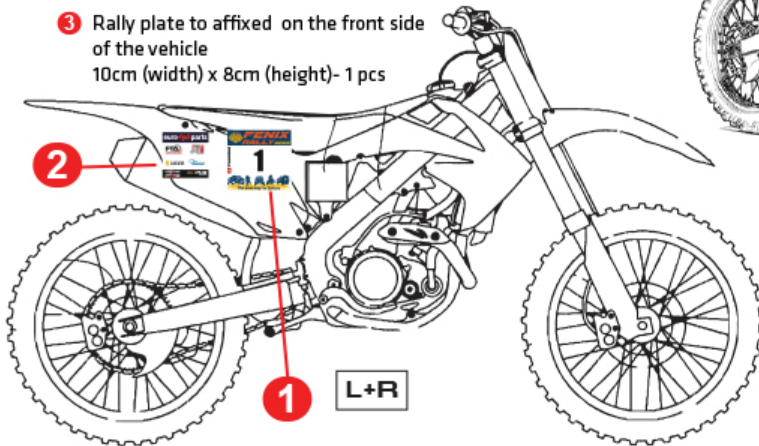

- 4 BIB number 26 x 30 cm - vinyl plate which should be clearly worn on the rider's back. The upper edge of the back bib must be a maximum of 20 cm from the neck of the rider and shall be always visible and not be hidden by anything, like a "Camel Bag".

ATV

- 1 Number plate stickers at the front and to be affixed on the lateral sides of the vehicle
15cm (width) x 14cm (height)- 3 pcs
- 2 Advertising plates to be affixed on the lateral sides of the vehicle
12cm (width) x 12cm (height) - 2 pcs
- 3 Rally plate to be affixed on the front side of the vehicle
10cm (width) x 8cm (height)- 1 pcs

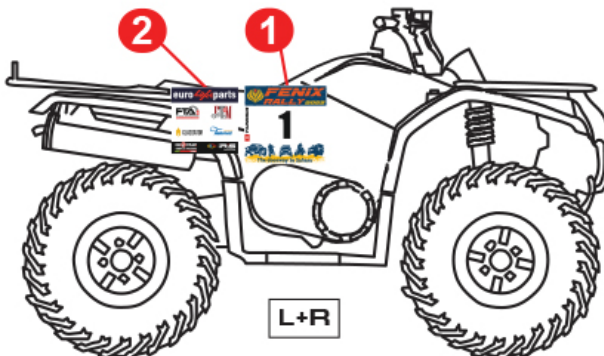

- 4 BIB number 26 x 30 cm - vinyl plate which should be clearly worn on the rider's back. The upper edge of the back bib must be a maximum of 20 cm from the neck of the rider and shall be always visible and not be hidden by anything, like a "Camel Bag".

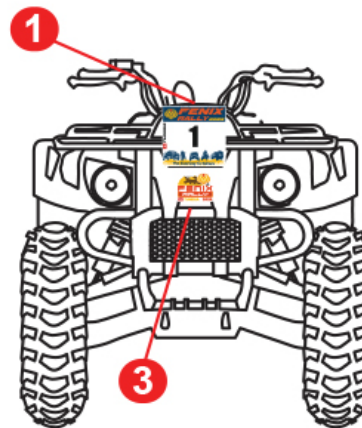

RBI SPORT - STICKER PLAN

- 1 Number plate stickers to be affixed on the lateral sides of the vehicle
30cm (width) x 28cm (height) - 2pcs
- 2 Sunvisor sticker
180cm (width) x 8cm (height) - 1 piece
- 3 Collective advertising plates
30cm (width) x 28cm (height) - 2pcs
- 4 Roof plate at the roof of the vehicle
42cm (width) x 40cm (height) - 1 piece

SSV

- 5 Rally plate at the front of the vehicle
22cm (width) x 18cm (height) - 1 piece
- 6 Number plate for photographers. Should be always visible from the front.
24cm (width) x 16cm (height) - 1pcs

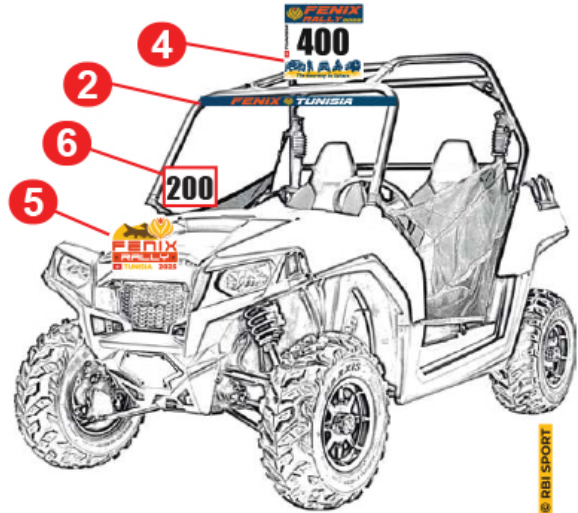
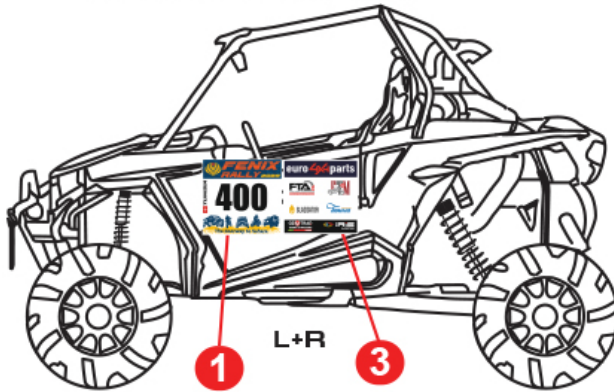

RBI SPORT - STICKER PLAN

- 1 Number plate stickers to be affixed on the lateral sides of the vehicle
42cm (width) x 40cm (height) - 2pcs
- 2 Sunvisor sticker
180cm (width) x 8cm (height) - 1 piece
- 3 Collective advertising plates
50cm (width) x 47cm (height) - 2pcs

CARS

- 4 Rally plate at the front and rear of the vehicle
37cm (width) x 30cm (height) - 2 piece
- 5 Roof plate at the roof of the vehicle
42cm (width) x 40cm (height) - 1 piece

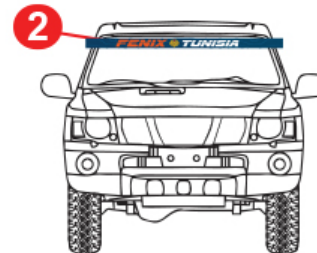
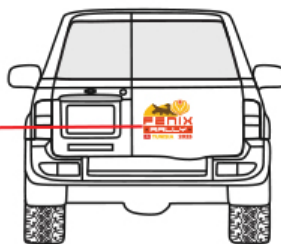
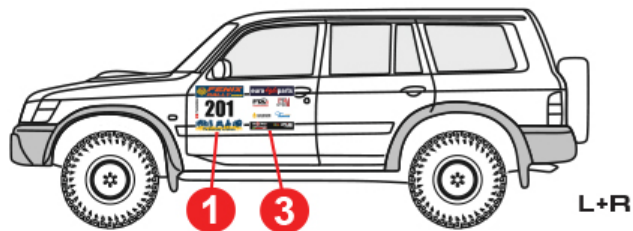

TRUCKS

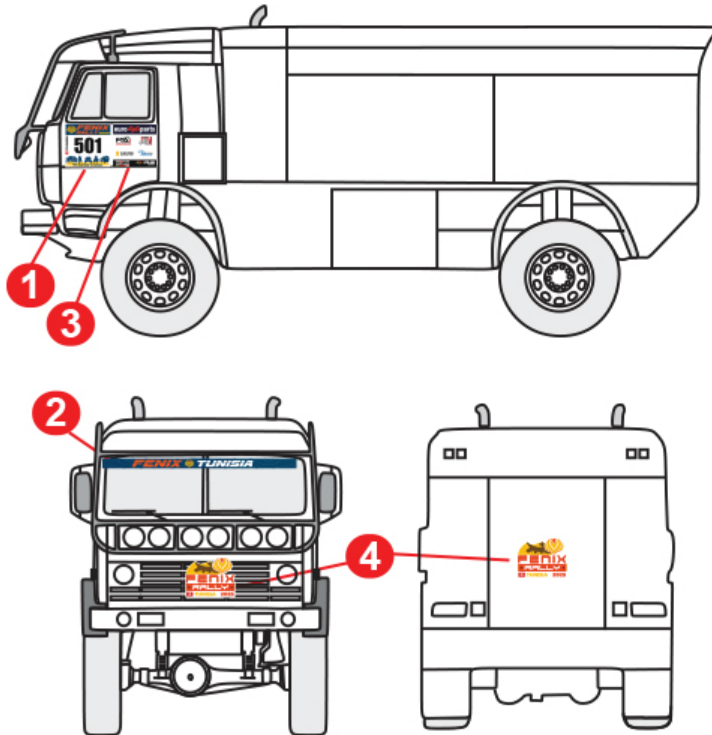

L+R

- 1 Number plate stickers to affixed on the lateral sides of the vehicle
50cm (width) x 47cm (height)- 2pcs
- 2 Sunvisor sticker
180cm (width) x 8cm (height) - 1piece
- 3 Collective advertising plates
50cm (width) x 47cm (height)- 2pcs
- 4 Rally plates at the front and rear of the vehicle 37cm (width) x 30cm (height)
- 2pcs

Appendix 4 – FERRY INFORMATION

Information about the participants who have booked ferry through RBI Group

Outbound trip – Ferry operator GNV:

Starting from Genoa on 29/10/2025 at 18:00 h ->

Arriving in Tunis on 30.10.2025 at 19:30 h.

You have to be at the port in the morning not later than 11:30 am.

Tickets will be distributed by email from NetFerry and GNV on 27/10/2025.

Return trip – Ferry operator CTN:

Starting from Tunis on 07.11.2025 at 11:00 h in the morning ->

Arriving in Genoa on 08.11.2025 at 13:00 h

You have to be at the port in the morning not later than 04:30 am.

You will not receive individual tickets for the return.

The ticket is for the entire group. The list includes people and vehicles.

MANDATORY FOR ALL COMPETITORS

SOS / OK Board – (DIN A3 Format) – Mandatory for all competitors to be printed out by themselves and be available in the vehicles.

Here you can download the board: <https://rbi-sport.com/Documents/RBI-OK--SOS.pdf>

Please print it in color in A3 format and prepare it as a part of the equipment for the rally.

Overview for illustrative purposes only.



**If you stop on a special stage and DO NOT REQUIRE MEDICAL ASSISTANCE,
please display this sign prominently!**

© Copyright















**If you stop on a special stage and REQUIRE MEDICAL ASSISTANCE,
please display this sign prominently!**

© Copyright

Appendix 6 - CONTROL SIGNS

2 SIGNALISATION DES CONTROLES

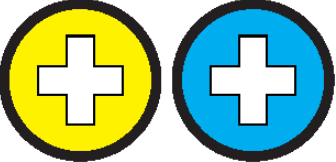
2 CONTROL SIGNS

<p>TIME CONTROL CONTRÔLE HORAIRE</p>  <p>Color of control area entry: YELLOW Color of control: RED Couleur de début de zone : JAUNE Couleur du contrôle : ROUGE</p>	<p>SS START DEPART DE SS</p>  <p>Color of control area entry: YELLOW Color of control: RED Couleur de début de zone : JAUNE Couleur du contrôle : ROUGE</p>	<p>FLYING FINISH LINE LIGNE D'ARRIVEE LANCEE</p>  <p>Color of control area entry: YELLOW Color of control: RED Couleur de début de zone : JAUNE Couleur du contrôle : ROUGE</p>
<p>STOP CONTROL CONTRÔLE STOP</p>  <p>Color: RED Couleur : ROUGE</p>	<p>PASSAGE CONTROL CONTRÔLE DE PASSAGE</p>  <p>Color of control area entry: YELLOW Color of control: RED Couleur de début de zone : JAUNE Couleur du contrôle : ROUGE</p>	<p>END OF AREA FIN DE LA ZONE</p>  <p>Color: BEIGE Couleur : BEIGE</p>
<p>REMOTE SERVICE ZONE ZONE D'ASSISTANCE ÉLOIGNÉE</p>  <p>Color: BLUE Couleur : BLEU</p>	<p>TYRE MARKING/CHECKING ZONE ZONE MARQUAGE/VERIFICATION PNEUS</p>  <p>Color: BLUE Couleur : BLEU</p>	<p>REFUEL ZONE ZONE DE RAVITAILLEMENT</p>  <p>Color: BLUE Couleur : BLEU</p>
<p>RADIO POINT POINT RADIO</p>  <p>Color of the warning: YELLOW Color of the point: BLUE Couleur de l'avertisseur : JAUNE Couleur du point : BLEU</p>	<p>MEDICAL VEHICLE POINT VEHICULE MEDICAL</p>  <p>Color of the warning: YELLOW Color of the point: BLUE Couleur de l'avertisseur : JAUNE Couleur du point : BLEU</p>	<p>MEDIA ZONE ZONE MEDIAS</p>  <p>Color: BLUE Couleur : BLEU</p>

Appendix 7 - CONTROL ZONE STANDARDS

ANNEXE X - NORMES POUR LES ZONES DE CONTROLE
APPENDIX X - CONTROL ZONE STANDARDS

ANNEXE X NORMES POUR LES ZONES DE CONTROLE	APPENDIX X CONTROL ZONE STANDARDS
---	--------------------------------------

**1 DEPART D'UN SECTEUR SELECTIF
CONFORMEMENT A L'ARTICLE 42**

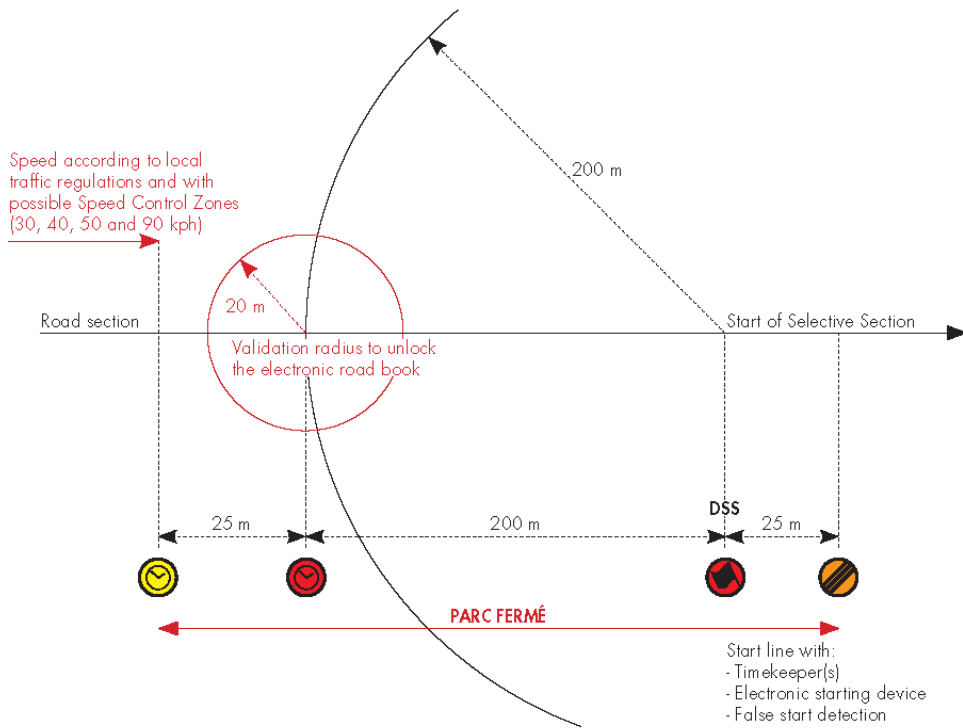

**1 START OF A SELECTIVE SECTION
AS PER ARTICLE 42**

**2 CONTROLE DE PASSAGE
CONFORMEMENT A L'ARTICLE 36.3**

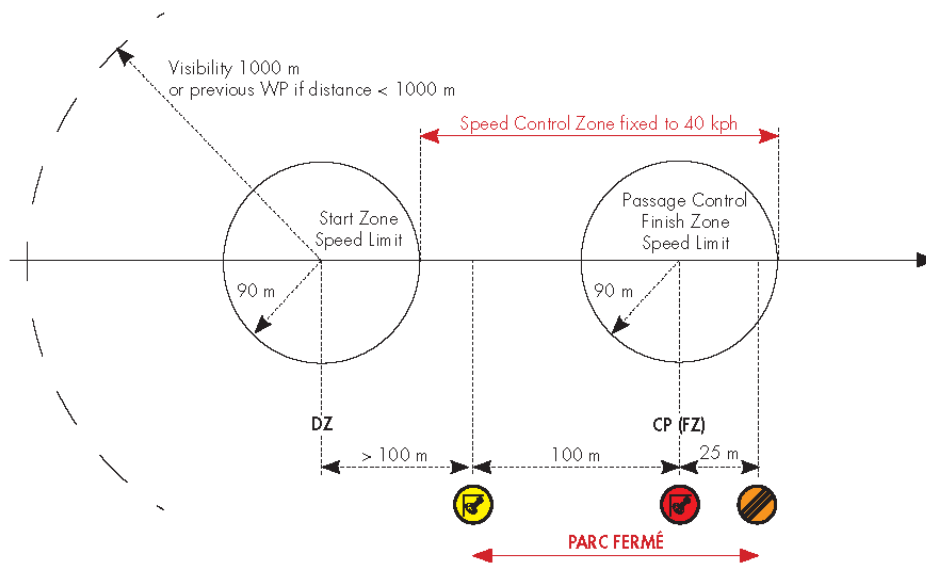

**2 PASSAGE CONTROL
AS PER ARTICLE 36.3**

2A CONTROLE DE PASSAGE
 CONFORMEMENT A L'ARTICLE 36.3 - ALTERNATIVE

2A PASSAGE CONTROL
 AS PER ARTICLE 36.3 ALTERNATIVE

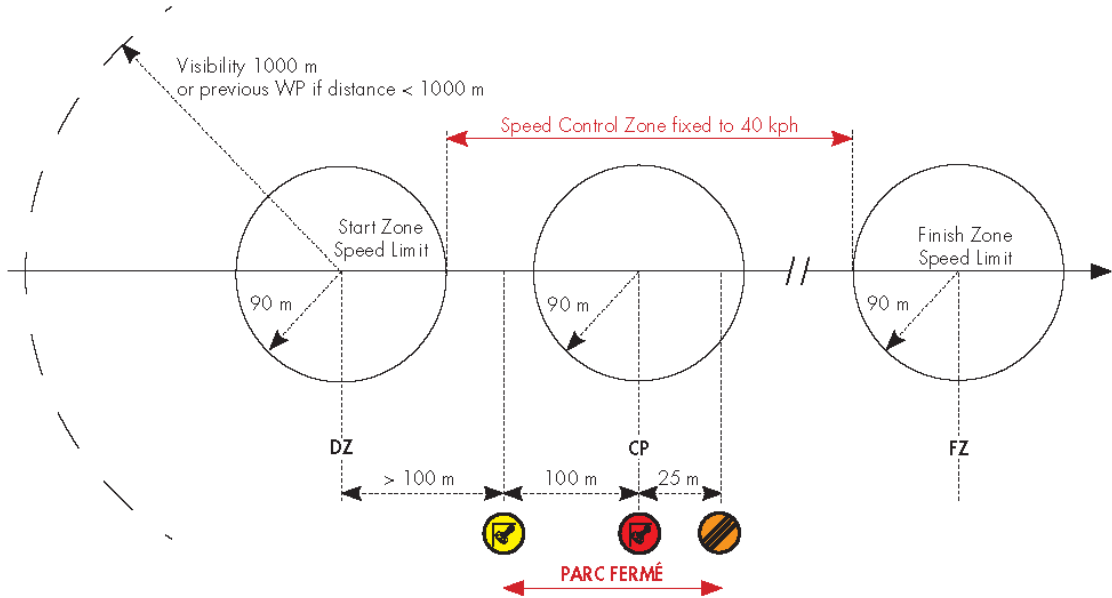

3 ZONE DE NEUTRALISATION ET RAVITAILLEMENT EN
 CARBURANT T3/T4 CONFORMEMENT A L'ARTICLE 45.1.2

3 T3/T4 NEUTRALISATION AND REFUELING ZONE
 AS PER ARTICLE 45.1.2

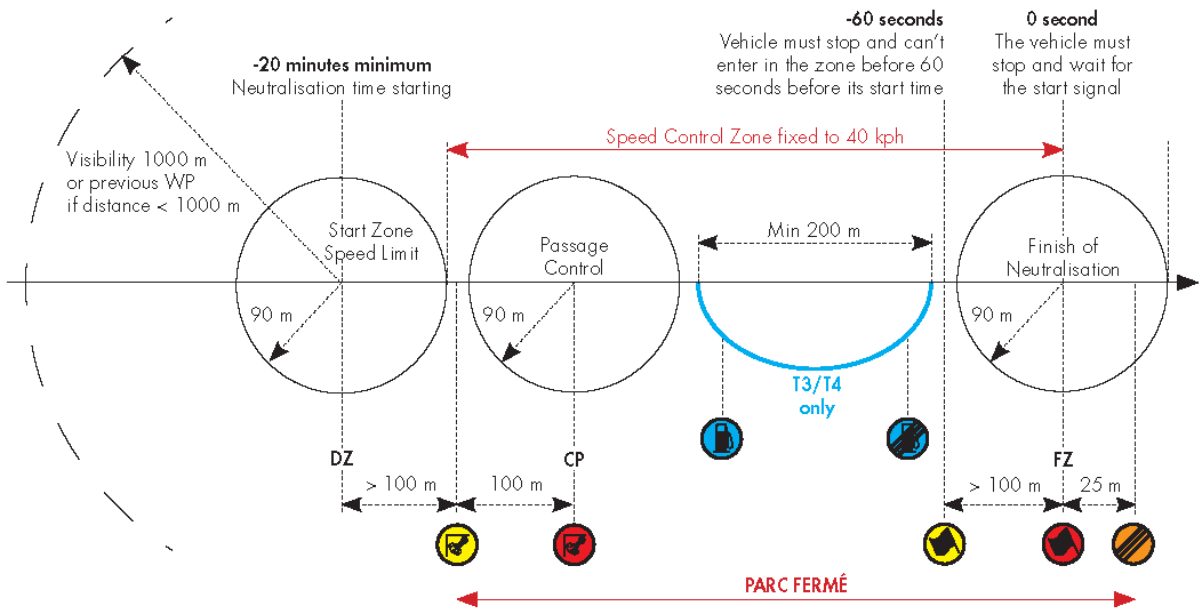

4 ZONE DE TRANSFERT CONFORMEMENT A L'ARTICLE 45.2

4 TRANSFER ZONE AS PER ARTICLE 45.2

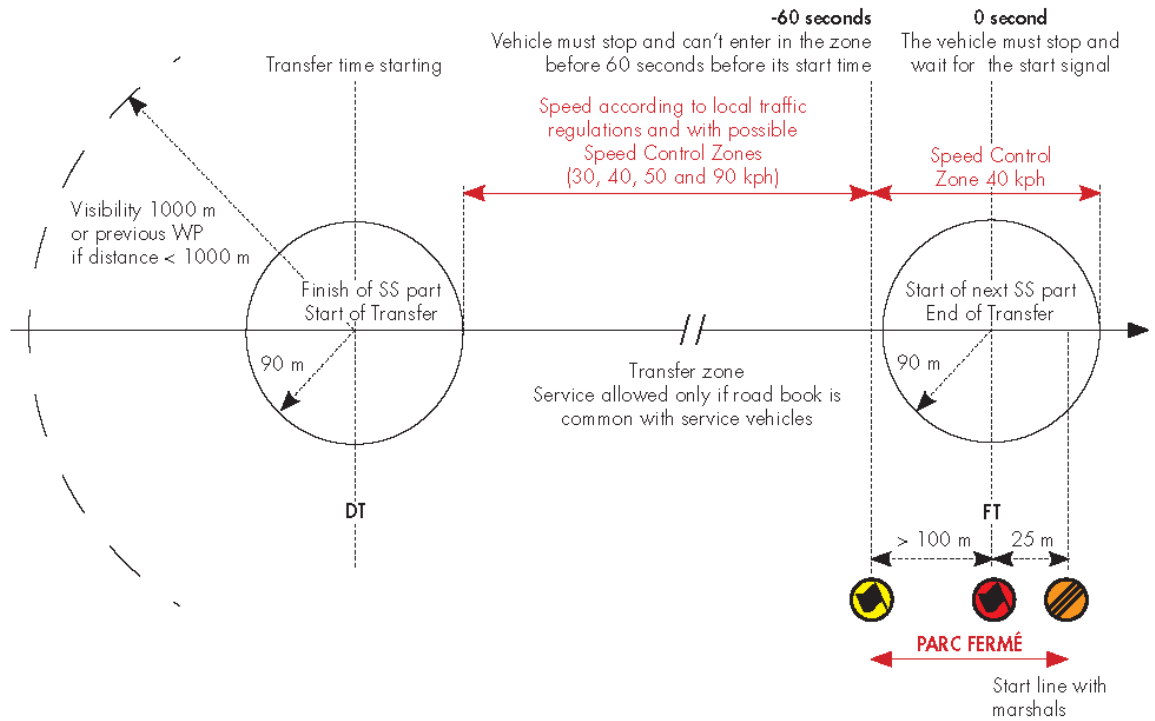





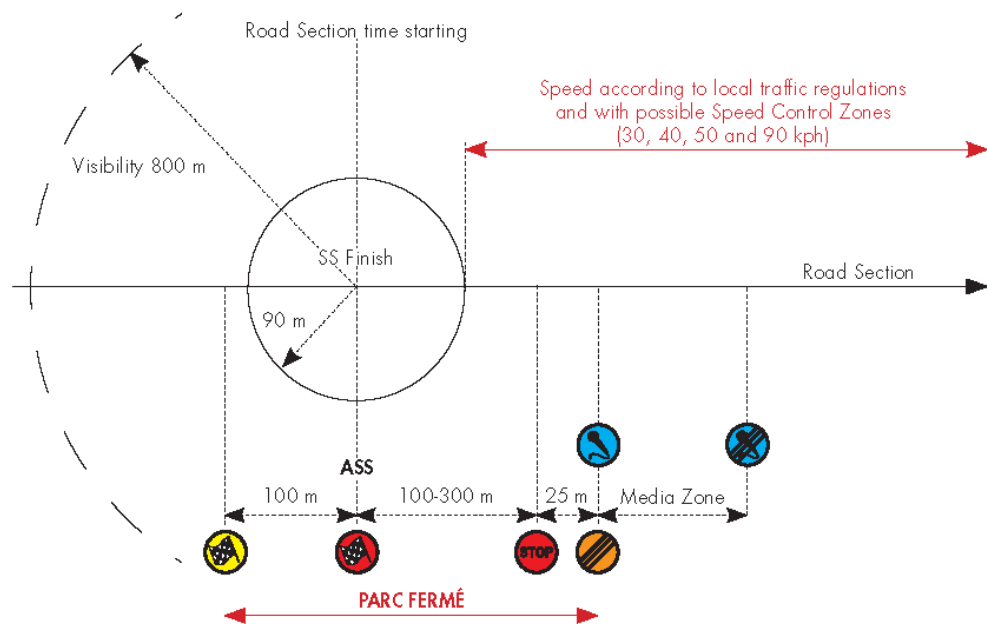











5 ARRIVEE D'UN SECTEUR SELECTIF CONFORMEMENT A L'ARTICLE 44

5 FINISH OF A SELECTIVE SECTION AS PER ARTICLE 44



Appendix 8 - ROAD BOOK ZONE SIGNAGE

ANNEXE III - DOCUMENTS STANDARD
APPENDIX III - STANDARD DOCUMENTS

Zone / Control	Roadbook box				Physical ground sign	NAV/SYS
	Waypoint	Distance	Diagram	Description		
SERVICE ZONE						
Service Area Zone Start and Finish					 Start  Finish	
SELECTIVE SECTION						
Start Selective Section	DSS			DSS	   	
Finish Selective Section	ASS			ASS	   	
MEDIA ZONE						
Media Zone Start and Finish					 Start  Finish	

Appendix 9 - ROAD BOOK LEXICON

ANNEXE III - DOCUMENTS STANDARD
APPENDIX III - STANDARD DOCUMENTS

5.14 LEXIQUE ROAD BOOK FIA

Seuls les symboles suivants doivent être utilisés. Les symboles nouveaux ou supplémentaires doivent être approuvés par la FIA.



5.14 FIA ROAD BOOK LEXICON

Only the following symbols must be used. New or additional symbols must be approved by the FIA.

TRACKS	WAYPOINTS	ON TRACK	SYMBOLS
Tarmac road	Masked WP	Bump	Fence
Track Piste	Control WP	Dip hole	Barbed fence
Off track (HP)	Security WP	Compression	Rail road
Low visible track / traces	Navigation WP	Ditch	Hole
P Track Piste	Precise WP	Summit	Collapse, ditch, ravine, etc.
PP Principal track/ piste	Visible WP	Above bridge	Ruts
RO Road	Eclipse WP	Under bridge	Twisty / sinuous
P// Parallel track/piste	Waypoint number	Step up	Bumpy / broken
HP Off track Sight driving!	CONTROLS	Step down	Bumpy
HP Off track forbidden	DSS Start Selective Section	Up hill Down hill	Lateral inclination
FPP Follow principal track/piste	ASS Arrival Selective Section	Cut danger	Post
FRO Follow road	CP Check point	Right or Left over crest	Electric pole
SA Sandy	DN FN Start/Finish Neutralisation	Fence gate	Electric line
GV Gravel	DN Start neutralisation with speed limit	Fence with cattle gate	High voltage tower
SAFETY	DT FT Start/Finish Transfer	Wall gate	Antenna
Danger Level 1	DT Start transfer with speed limit	Wading / water cross	Well
Danger Level 2	T:25 Neut./transfer max. time allowed	Concrete pass	Tanks
Danger Level 3	Waiting for restart	CAPS	Barrels
Global danger in the note	Stop for restart	CAP Exit cap	Notable elements
DZ 40 Start Speed limit	MQ/T3/T4 Fuel zone with authorized cat.	CAP_A Average cap	Tires
FZ 40 Finish Speed limit	Time control	CAP_C Calculated cap (only HP)	Sign posts
Stop	Assistance Service	OBLIC Cap that turns	Restricted/protected area
Important	Tyre marking zone		Buildings / houses
25.25 Red line under km = danger 2 in the note	End zone		Church / mosque

Appendix 10 - ROAD BOOK EXAMPLES

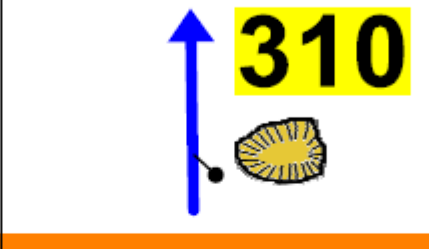
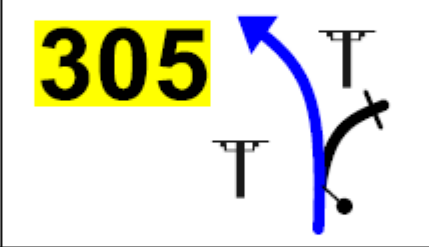
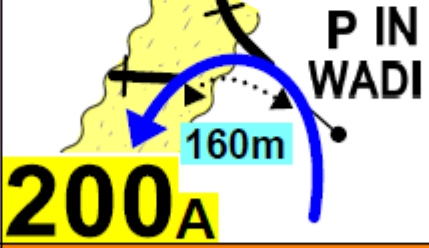
ANNEXE III - DOCUMENTS STANDARD
APPENDIX III - STANDARD DOCUMENTS

5.15 ROAD BOOK EXAMPLES		5.15 ROAD BOOK EXAMPLES	
17	ETAPE XX / XXXXXX - XXXXXX / SS	Km : 163,56	
60,92		30	FESH FESH (25)
0,56 (DZ)			
61,37		310	GO ALONG ELEC LINE
0,45 (FZ)		360	OBLIC 30/1km (26)
63,23		305	
1,86 ↓			
63,44		200_A	KpL
0,21 (C)			(27)
64,30		30	SWITCH VALLEY (28)
0,86 (DZ)			

Next 0,39

Exemple I (non à l'échelle) / Example I (not to scale)











103 - Published on 08.12.2022

18	ETAPE XX / XXXXX - XXXXX / SS		Km : 163,56
64,69		ET TJS PP SA 259	30 ^A (29)
0,39	FZ		
67,82		334 ET à 250m	315 ^A
3,13			
68,88		36 ^A NBX P// ET	38 ^A (30)
1,06	C		
MODIF <u>71,10</u>		290 ^A	
2,22			
71,49		360 ^A ET VALLEY	345 ^A
0,39			

Next 2,28

Exemple II (non à l'échelle) / Example II (not to scale)

Appendix 11 – TIME CARD - SAMPLE

LEG	START GROUP		TIME CARD	START NUMBER
DEPARTURE	TC BIVOUAC 	DEPARTURE H M	LS TARGET time H M	
		TC 	H M	
START ORDER				
SELECTIVE SECTION	MAX TIME H M	ARRIVAL H M S	TARGET TIME H M	© RBI
	PROVISIONAL START (+3) H M	DEPARTURE H M		
		TC 	H M	
	FINISH ORDER			
SELECTIVE SECTION	MAX TIME H M	ARRIVAL H M S	TARGET TIME H M	© RBI
	PROVISIONAL START (+3) H M	DEPARTURE H M		
		TC 	H M	
	FINISH ORDER			
SELECTIVE SECTION	MAX TIME H M	ARRIVAL H M S	TARGET TIME H M	© RBI
	PROVISIONAL START (+3) H M	DEPARTURE H M		
		TC 	H M	
	FINISH ORDER			

v1.0/23