

BEATSON'S BUILDING SUPPLIES MULL RALLY

Date : 7 October 2023

Time : 21.00 hrs

Subject : BULLETIN No. 2

From : The Clerk of the Course

To : All Competitors
(including attachments: Schedule TS 1.25)

Pages : 12

1. Amendments to Supplementary Regulations

1 Programme

Schedule During the Rally Week

Thursday 12th October		
10.30 - 18.00 11.00	Collection of material and documents	Aros Hall, Tobermory, PA75 6NU, ///coarser.unopposed.luxury
Friday 13th October		
09.00 - 13.00 09.30	Collection of material and documents	Aros Hall, Tobermory, PA75 6NU, ///coarser.unopposed.luxury

9.5 Refuelling

The event will operate two official Refuel Zones, with a specific site having been for secured Tobermory service during Leg 2, to reduce service traffic movements.

BEATSON'S BUILDING SUPPLIES MULL RALLY

Refuel Zone for Legs 1/3 is located at Isle of Mull Rugby Club, Garmony, PA65 6BA,
NM/ 6751 4062, [///momentous.cheek.broth](http://momentous.cheek.broth)



Refuel Zone for Leg 2 is located at Baliscate, Tobermory, PA75 6QA,
NM/ 5031 5456, [///punctuate.deflation.recapture](http://punctuate.deflation.recapture)

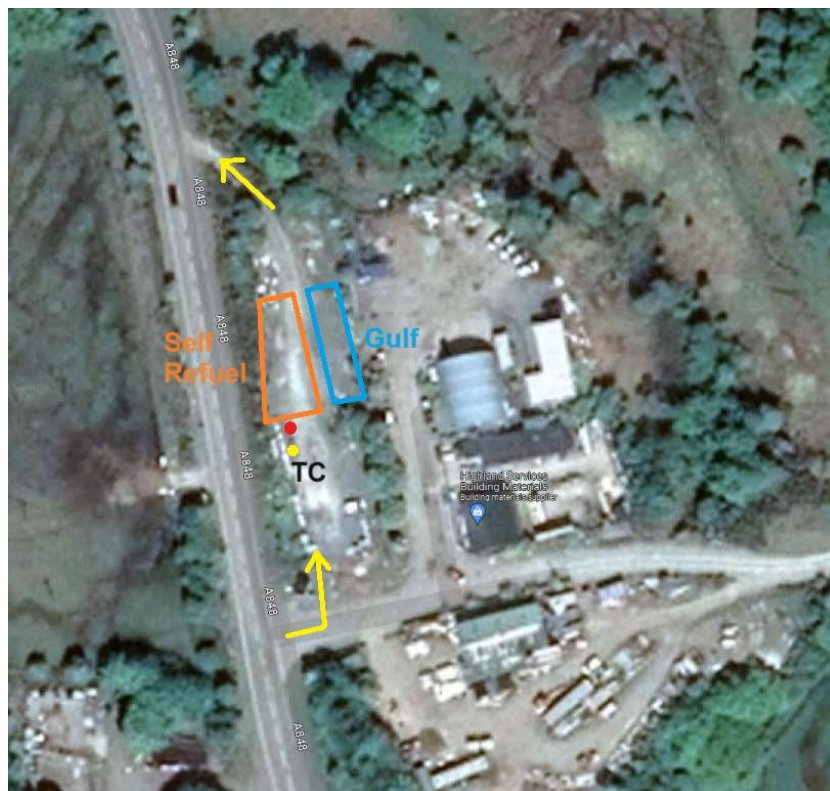

BEATSON'S BUILDING SUPPLIES MULL RALLY

Refuel Zone Opening Times

Friday 13 th October	07.30 - 16.15 // 17.10 - 20.30	Garmony	RZ1,2
Saturday 14 th October	07.30 - 14.30	Tobermory	RZ2A,3
Saturday 14 th October	16.00 - after final competitor (~23.55)	Garmony	RZ4,5,6

Competitors must ensure that they, and their service crews are fully aware of, and adhere to the refuelling rules:-

- Competitors may only refuel in the refuel zones defined in the road book, or by using commercially available pump fuel dispensed directly from pumps at filling stations on the rally route (locations as advised in Rally Guide 1).

- **For the avoidance of doubt, refuelling in the Service Parks is prohibited.**

- The refuelling zone will consist of a self-fuel area, where competitors will be able to refuel their vehicles using their own fuel brought to the event in an appropriate British Standard approved fuel container.

- Owing to space requirements, to reduce the total fuel contained within the Refuel Zone at a given time, all fuel for each leg must be deposited with the Refuel Zone Officer in the refuel area between:

Leg 1 – 07.30 and 16.10 on Friday 13th October

Leg 2 – 07.30 and 11.00 on Saturday 14th October

Leg 3 – 16.00 and 17.45 on Saturday 14th October

- When depositing fuel, ensure that cans are labelled with your car number (the Refuel Zone Officer & team may be able to assist with labelling) and that the Refuel Zone Officer is informed of the number of cans being deposited.

- Tagged fuel containers will be logged and released for use to the Competitor's nominated person(s) only.

- The responsibility for refuelling is incumbent on the competitor alone

- Each crew is allowed 2 nominated persons for the purpose of refuelling, and they will be permitted entry up to 5 minutes prior to their competition car - no other personnel will be permitted to enter the Refuel Zone.

- The Refuel Zone will open 07.30-08.30 on Friday 13th to allow for fuel to be taken prior to Shakedown/Scrutineering, and until 17.00 to allow for fuel to be taken for Scrutineering / prior to the start

- It is not permitted to transport fuel across the Service Parks whilst the rally is in progress.

- No one under the age of 17 will be allowed in the Refuel Zone.

- No sources of ignition, naked flame etc may be brought into the refuelling area.

- Containers should comply with the relevant British Standard, should be marked "Petroleum Spirit-Highly Flammable" and be kept from any source of ignition.

- All empty containers should be removed from the venue after the event

- Fire Extinguishers will be on hand at the Refuel Zone.

- Petrol is to be used as vehicle fuel only, not for any other purpose.

When refuelling

1. There will be a strict maximum 5MPH limit in the refuel zone.

2. Refuelling operatives, including those standing by, should ensure they are wearing protective clothing, including suitable non-absorbent gloves and eye protection.

3. Refuelling must be either by pump or from MOD/UN specification 20 litre jerry cans with the purpose made flexible metal spouts. **Funnels are NOT permitted.**

4. No other activity is permitted in the refuelling areas and the vehicle must have all four wheels on the ground – Judges of Fact will be present to monitor compliance.

BEATSON'S BUILDING SUPPLIES MULL RALLY

5. On entering the refuel area competitors will be directed to a refuel bay.
6. Empty cans may be removed, but only with the express permission of the Refuel Zone Officer
7. If a car fails to start within the refuel area it must be moved out of the area before ANY work is carried out.
8. Refuelling must not commence until there are **no occupants** in the vehicle.
9. Engines must be switched off throughout the refuelling process.

Keep off of the grass in the vicinity of the Refuel Zones.

Please note that permission can be obtained to retrieve your fuel canisters during the event if you are forced to retire, by asking the permission of the event Motorsport UK Environmental Scrutineer / Refuel Zone Officer (refuel@mullrally.org). They will give clear instructions on how these containers can be collected.

Any competitor found in breach of refuelling area procedures will be subject to the following penalties.

For late deposit of self-refuel canisters and/or moving of fuel canisters around the Service Parks during the event, or breach of Refuel Area Safety Rules 1 to 7 or if you are found refuelling in an area other than the Refuel Zone, or by using commercially available pump fuel dispensed directly from pumps at filling stations on the rally route, the penalties are as follows:

- First Offence – Reported to the Clerk of the Course
- Second Offence – Disqualification from the event

For breach of Refuel Area Safety Rules 8 and 9 (R.38.1.7):

- Disqualification and reported to Motorsport UK

For any queries on the Refuel Zone procedures, please liaise with Peter Clingan (Motorsport UK Environmental Scrutineer / Refuel Zone Officer) at refuel@mullrally.org

11.3 Eligibility for Awards

Winners of ~~Class C~~ Class 4

Paul Tomlins Memorial Trophy

Susan Cameron Trophy

This will be awarded to the highest placed co-driver in a ~~Class A~~ Class 6 car.

2. Amendments to Road Book









Service A & Garmony Refuel Zones



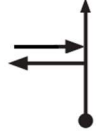



Owing to impassable footpath between auxiliary and main car park, the Refuel Zone at Garmony has been repositioned.

In addition for Service A, to simplify traffic flows, and to ensure sporting parity among those wishing to service north vs south of Garmony, TC 2D Service Out has been moved to the western exit of Salen, and Refuel Zone 2 is now within service park / service time.

With reference RS 2C - RS 2D, RS 9B - RS 9C, and RS13B - RS13C, please replace / modify Road Book pages 37-40, 69-72, and 95-99, with the following:







BEATSON'S BUILDING SUPPLIES MULL RALLY

RS	TC 2C Service A - In		TC 2D Service - Out			
2C	Distance	11.55 Miles	Time	0 hr 53 min	Speed	13.07 Mph
	Total	Partial	Direction	Information	Miles to TC	
	0.00	0.00		 TC 2C Service A - In <small>N 56° 27.997' W 05° 41.915' //trades.hikes.jaws</small>	11.55	1
	4.10	4.10		Refuel Zone on left <small>N 56° 30.005' W 05° 46.750' //momentous.cheek.broth</small>	7.45	2
	11.02	6.92		 (Salen)	0.53	3
	11.34	0.32		 Gruline 2½ Kinloch 21 B 8035 Ulva Ferry 9 (B 8073)	0.21	4
	11.55	0.21		 TC 2D Service - Out Keep driveways clear <small>N 56° 30.851' W 05° 56.809' //bring.exist.thousands</small>	0.00	5

RS	TC 2D Service - Out		TC 3 Hill Road / Glen Aros			
2D	Distance	13.80 Miles	Time	0 hr 45 min	Speed	18.40 Mph
	Total	Partial	Direction	Information	Miles to TC	
	0.00	0.00		 TC 2D Service - Out <small>N 56° 30.851' W 05° 56.809' //bring.exist.thousands</small>	13.80	1
	2.26	2.26			11.54	2
	8.77	6.51		Ulva School	5.03	3
	13.54	4.77		Torloisk	0.26	4
	13.80	0.26		 TC 3 <small>N 56° 31.896' W 06° 12.202' //widest.absent.singled</small>	0.00	5

BEATSON'S BUILDING SUPPLIES MULL RALLY



RS		TC 9B Salen - Restart		TC 9C Garmony Refuel - In			
9B		Distance	7.30 Miles	Time	0 hr 16 min	Speed	27.37 Mph
Distance		Direction		Information		Miles to TC	
Total	Partial						
0.00	0.00	 Salen Hotel		 TC 9B Restart N 56° 31.021' W 05° 56.809' //adjusted.interests.wink		7.30	
		1					
6.67	6.67					0.63	
		2					
7.25	0.58					0.05	
		3					
7.30	0.05			 TC 9C Refuel - In N 56° 30.005' W 05° 46.750' //momentous.cheek.broth		0.00	
		4					











BEATSON'S BUILDING SUPPLIES MULL RALLY







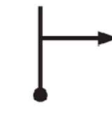

RS		TC 9C Garmony Refuel - In		TC 10 Loch Kinloch 1			
9C		Distance	20.85 Miles	Time	0 hr 45 min	Speed	27.80 Mph
Distance		Direction		Information		Miles to TC	
Total	Partial						
	1						
0.00	0.00			Join A849			20.85
	2						
3.44	3.44						17.41
	4						
20.70	17.26						0.15
	5						
20.85	0.15						0.00
	6						

BEATSON'S BUILDING SUPPLIES MULL RALLY



RS	TC 13B Tobermory Regroup - Out	TC 13C Garmony Refuel - In		
13B	Distance 17.00 Miles	Time 0 hr 35 min		
		Speed 29.14 Mph		
Distance		Direction	Information	Miles to TC
Total	Partial			
0.00	0.00		 <p>TC 13B Regroup - Out</p> <p>N 56° 37.225' W 06° 04.142' //strikers.demoted.kick</p>	17.00
		1		
0.06	0.06			16.94
		2		
0.30	0.24		 <p>Salen 9 A 848 21 Craignure 53 Iona Ferry (A 849)</p>	16.70
		3		
8.10	7.80			8.90
		4		
9.50	1.40		 <p>(Salen)</p>	7.50
		5		
16.95	7.45			0.05
		6		
17.00	0.05		 <p>TC 13C Refuel - In</p> <p>N 56° 30.005' W 05° 46.750' //momentous.cheek.broth</p>	0.00
		7		

RS	TC 13C Garmony Refuel - In	TC 13D Service C - In		
13C	Distance 3.44 Miles	Time 0 hr 15 min		
		Speed 13.76 Mph		
Distance		Direction	Information	Miles to TC
Total	Partial			
			 <p>TC 13C Refuel - In</p> <p>N 56° 30.005' W 05° 46.750' //momentous.cheek.broth</p>	
		1		
0.00	0.00		Join A849	3.44
		2		
3.44	3.44		  <p>TC 13D Service C - In</p> <p>N 56° 28.330' W 05° 42.565' //masts.marble.gurgling</p>	0.00
		3		

BEATSON'S BUILDING SUPPLIES MULL RALLY

Refuel Zone 2

Rename Refuel Zone prior TC 3B, from 'RZ 2' (duplicate) to 'RZ 2A'.

Event Time Schedule

Event Time Schedule – Road Book pages 4-6 – is updated to that included as attachment.

Time Card Collections

Competitors will be required to hand in time cards at Passage Controls following stages. In addition, please mark in the road book at the following TC locations, the requirement to hand in timecards:

p21, box 5 TC 0A Hand in Timecard No. 1
p37, new box 5 TC 2D Hand in Timecard No. 4
p45, box 5 TC 3A Hand in Timecard No. 5 & 6

p61, box 5 TC 6C Hand in Timecard No. 10
p65, box 5 TC 9A Hand in Timecard No. 14

p69, new box 4 TC 9C Hand in Timecard No. 15
p91, box 6 TC 13A Hand in Timecard No. 19
p95 new box 7 TC 13C Hand in Timecard No. 20
p101, box 1 TC 13E Hand in Timecard No. 21
p103, box 6 TC 17A Hand in Timecard No. 25 & 26

3. Amendments to Time Cards

RS 2C / RS 2D

In support of the aforementioned changes to Service A / RS 2C, and RS 2D, please ensure the following changes are made to Time Cards:

Timecard No. 4 TC 2C to TC 2D Target Time: Delete 0:43, add 0:53
Timecard No. 5 TC 2D to TC 3 Target Time: Delete 0:55, add 0:45

Submission of Queries

The Results Officer has requested that, in instances where competitors may submit photographs of time card 'stubs' ('For Competitor Use' section) to CLOs in case of queries, that they please ensure the car number is written legible on the stub / within the photograph, for ease of identification.



Richard Crozier
Clerk of the Course

BEATSON'S BUILDING SUPPLIES MULL RALLY



BEATSON'S BUILDING SUPPLIES MULL RALLY 2023		2023 BEATSON'S BUILDING SUPPLIES MULL RALLY			
		1.25	7 October 2023		
Shakedown		Friday 13 October 2023			
Sunrise 07:49		Sunset 18:30			
TC	Location	SS	Liaison	Target	First Car
SS		Miles	Miles	Time	Due
	Shakedown Service - Duart Castle	-	-		
	Shakedown Start	-	0.03		
	Western Isles Hotel				
SD	Shakedown Stage - Duart E-W	1.57	-	Session 1	09:00 / 12:00
	TSL Quarry		0.18		
	Western Isles Hotel				
SD	Shakedown Stage - Duart W-E	1.57	-		
	Shakedown Service - Duart Castle	-	0.08		
SHAKEDOWN TOTALS		3.14	0.29		
		(91.55%)	(8.45%)		
Sections 1 & 2					
Sunrise 07:49		Sunset 18:30			
TC	Location	SS	Liaison	Target	First Car
SS		Miles	Miles	Time	Due
RZ	Refuel - Garmony		(17.30)		
1	Distance to next refuel	(8.75)	(58.68)		
0	Start - Tobermory				14:30
0A	Ceremonial Start - Tobermory		0.60	00:15	14:45
1	JD Mounsey		13.70	00:36	15:21
SS 1	Ben More			(00:03)	15:24
SF1		4.44			
2	Groundwater Lift Trucks		6.19	00:22	15:49
SS 2	Scridain			(00:03)	15:52
SF2		4.31			
2A	TSL Regroup IN		15.48	00:41	16:36
	TSL Regroup			00:25	
2B	Regroup OUT		0.05		17:01
2C	Service IN		1.26	00:17	17:18
	Service A (Craignure - Salen)	(8.75)	(37.28)	00:53	
RZ	Refuel - Garmony		(4.10)		
2	Distance to next refuel	(8.01)	(28.53)		
2D	Service OUT		11.55		18:11
3	Inverlussa Marine Services		13.80	00:45	18:56
SS 3	Hill Road / Glen Aros			(00:03)	18:59
SF3		8.01			
3A	Salen Hotel		7.49	00:30	19:35
FRIDAY TOTALS (3 SS)		16.76	70.12		
		(19.29%)	(80.71%)		

Section 1

Section 2

BEATSON'S BUILDING SUPPLIES MULL RALLY



BEATSON'S BUILDING SUPPLIES MULL RALLY 2023		2023 BEATSON'S BUILDING SUPPLIES MULL RALLY			
		1.25	7 October 2023		
Sections 3 & 4 - 30 second intervals					Saturday 14 October 2023
Sunrise 07:53					Sunset 18:25
TC	Location	SS	Liaison	Target	First Car
SS		Miles	Miles	Time	Due
RZ	Refuel - Tobermory	-	(0.53)		
2A	Distance to next refuel	(26.73)	(16.28)		
3B	Restart - Tobermory				09:20
4	Duffy Skylining		0.75	00:07	09:27
SS 4	Mishnish Lochs 1			(00:03)	09:30
SF4		6.26			
5	Screencraft		1.11	00:09	09:46
SS 5	Calgary Bay 1			(00:03)	09:49
SF5		10.12			
6	Viking Offshore		0.21	00:07	10:06
SS 6	Black Rose 1			(00:03)	10:09
SF6		10.35			
6A	Tobermory Regroup IN		13.10	00:34	10:51
	Tobermory Regroup			00:12	
6B	Tobermory Regroup OUT		0.05		11:03
Service B (Tobermory)		(26.73)	(15.22)	00:28	
6C	Service OUT - Refuel IN		0.53		11:31
RZ	Refuel - Tobermory				
3	Distance to next refuel	(26.73)	(5.21)		
7	Duffy Skylining		0.58	00:11	11:42
SS 7	Mishnish Lochs 2			(00:03)	11:45
SF7		6.26			
8	Screencraft		1.11	00:09	12:01
SS 8	Calgary Bay 2			(00:03)	12:04
SF8		10.12			
9	Viking Offshore		0.21	00:07	12:21
SS 9	Black Rose 2			(00:03)	12:24
SF9		10.35			
9A	Salen Hotel		3.31	00:13	12:45
SATURDAY DAY TOTALS (6 SS)		53.46	20.96		
		(72.03%)	(27.97%)		

Section 3

Section 4

BEATSON'S BUILDING SUPPLIES MULL RALLY



BEATSON'S BUILDING SUPPLIES MULL RALLY 2023		2023 BEATSON'S BUILDING SUPPLIES MULL RALLY			
		1.25	7 October 2023		
Sections 5 & 6		Saturday 14 October 2023			
Sunset 18:25		Sunrise 07:55			
TC	Location	SS	Liaison	Target	First Car
SS		Miles	Miles	Time	Due
RZ 4	Refuel - Garmony [Closes 17:30] Distance to next refuel		(7.30) (14.60)		
9B	Restart - Salen Hotel				17:55
9C	Refuel IN		7.30	00:16	18:11
RZ 5	Refuel - Garmony Distance to next refuel	(31.96)	(53.05)		
10	Mayfield Garage Services		20.85	00:45	18:56
SS 10	Loch Kinloch 1			(00:03)	18:59
SF10		4.31			
11	Motorwise		6.35	00:21	19:23
SS 11	Knock 1			(00:03)	19:26
SF11		4.79			
12	Scottish Gritting		6.50	00:23	19:52
SS 12	Lagganulva / Mornish 1			(00:03)	19:55
SF12		16.63			
13	Electrical Switchgear Services		1.46	00:11	20:21
SS 13	Achnadriish 1			(00:03)	20:24
SF13		6.23			
13A	Tobermory Regroup IN		0.80	00:09	20:40
	Tobermory Regroup			00:20	
13B	Tobermory Regroup OUT		0.05		21:00
13C	Refuel IN		17.00	00:35	21:35
RZ 6	Refuel - Garmony Distance to next refuel	(31.96)	(35.37)		
13D	Service IN		3.44	00:15	21:50
	Service C (Craignure)	(31.96)	(63.79)	00:30	
13E	Service OUT				22:20
14	Mayfield Garage Services		16.83	00:36	22:56
SS 14	Loch Kinloch 2			(00:03)	22:59
SF14		4.31			
15	Motorwise		6.35	00:21	23:23
SS 15	Knock 2			(00:03)	23:26
SF15		4.79			
16	Scottish Gritting		6.50	00:23	23:52
SS 16	Lagganulva / Mornish 2			(00:03)	23:55
SF16		16.63			
17	Electrical Switchgear Services		1.46	00:11	00:21
SS 17	Achnadriish 2			(00:03)	00:24
SF17		6.23			
17A	Tobermory		0.70	00:09	00:40
SATURDAY NIGHT TOTALS (8 SS)		63.92	95.59		
		(40.07%)	(59.93%)		

TOTALS OF THE RALLY			
	SS	Liaison	%
Friday 13 October	16.76	70.12	19.3%
Saturday 14 October	53.46	20.96	71.8%
Saturday 14 October	63.92	95.59	40.1%
Total - 17 SS	134.14	186.67	41.8%

Section 5

Section 6